

Integrated and Separate Type In Situ Zirconia Oxygen/
High Temperature Humidity Analyzer
ZR202G/S, ZR402G, ZR22G/S
Averaging Converter
AV550G



ZR202G/S, ZR402G, ZR22G/S

Integrated and Separate Type In Situ Zirconia Oxygen/High Temperature Humidity Analyzer

AV550G

Averaging Converter

EXAxti

Bulletin 11M12A01-01E

www.yokogawa.com/an/

vigilantplant.[®]
The clear path to operational excellence

YOKOGAWA 

Yokogawa presents zirconia oxygen analyzers for saving energy and environmental protection

Get a Long Service Life and Stable Operation with a Zirconia Sensor Sensor Replacement is Easy

- A molecular bonding method completes installation of platinum electrodes, and its inherent connection prevents separation of platinum from the zirconia element.
- A lead-less electrode design eliminates electrical disconnection.
- Special coating protects the platinum and prevents the sensors from deteriorating or becoming damaged.
- No special tool is required for cell replacement. Whenever required, the cell is easily removed by removing four screws from the top of the probe. Down time ("from the time installation is started until it is completed") is minimized to approximately ten minutes. After the cell is replaced, the analyzer requires a zero and span calibration only once.

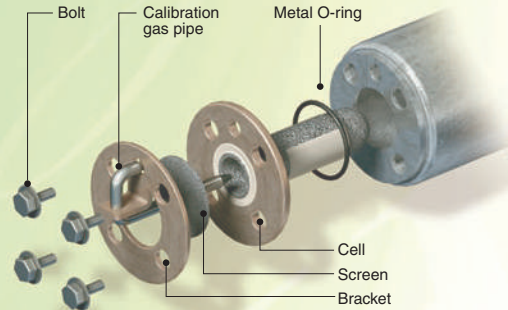
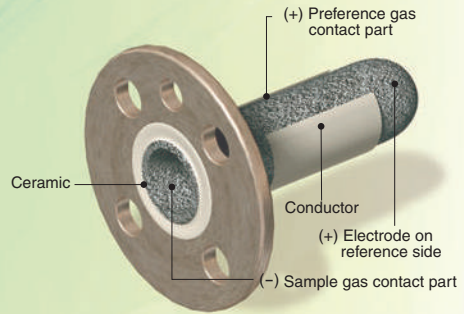

ZR202G/S

ZR22G/S

ZR402G

Principle of Zirconia Oxygen Analyzer

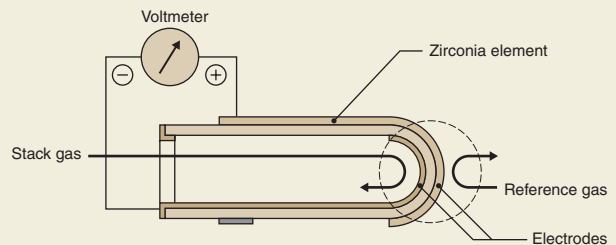

The principle of the zirconia oxygen analyzer is as follows:
At high temperatures the zirconia element, as a solid electrolyte, is a conductor of oxygen ions. Platinum electrodes are attached to the interior and exterior of the zirconia. Heating the element allows different partial oxygen concentrations of gases to come into contact with the opposite side of the zirconia creating an oxygen concentration cell. In other words, oxygen molecules gain electrons to form oxygen ions with higher partial oxygen concentrations. These ions travel through the zirconia element to the other electrode. At that point, electrons are released to form oxygen molecules (refer to the chemical formula). The Nernst expression can be applied to calculate the force by measuring the electromotive force E generated between the two electrodes.

Electrode with high oxygen partial pressure: $O_2 + 4e \rightarrow 2O^{2-}$ (Reference side)
Electrode with low oxygen partial pressure: $2O^{2-} \rightarrow O_2 + 4e$ (Measuring side)
Reactive electromotive force E(V) can be derived from Nernst's formula.

$$E = - \frac{RT}{nF} \ln \frac{P_x}{P_A}$$

R: Gas constant; T: Absolute temperature; n: 4; F: Faraday's constant;
Px: Oxygen partial pressure of zirconia element on the measuring gas side(%);
PA: Oxygen partial pressure of zirconia element on the reference gas side(%);
Atmospheric air: 20.6(%); Instrument air: 21.0(%)

For the ZR22 cell, temperature is 750°C and the correspondingly reactive electromotive force E =

$$E = -50.74 \log \frac{P_x}{P_A} \text{ [mV]}$$

$$P_x = P_A \cdot 10^{\frac{E}{50.74}}$$

ZR202G/ZR202S

Integrated Type In Situ Zirconia Oxygen / High Temperature Humidity Analyzer

- Can cut wiring, piping and installation costs.
- Can be operated in the field without opening the cover using an infrared switch.
- Allows replacement of the zirconia cell and heater in the field.
- Can measure either oxygen concentration or humidity with a single analyzer.
- Remote maintenance using digital communication reduces maintenance cost.
- Explosionproof approval.

ATEX: EEx d IIB + H2, Group II, Category 2GD, T2, T300°C

FM/CSA: Class I, Division 1, Groups B, C and D,

Class II/III, Division 1, Groups E, F and G, T2

IECEX: Ex d IIB + H2 T2, Ex tD A21 IP66 T300°C

■ Automatic Calibration Unit

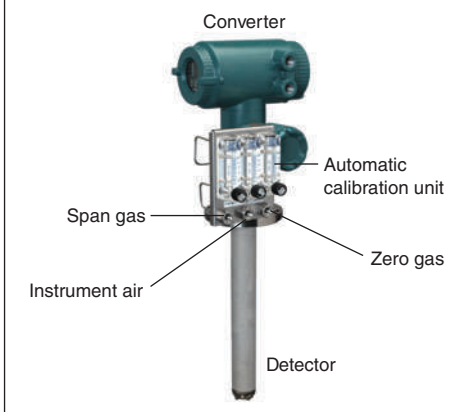

- The automatic calibration unit can be attached in the field easily

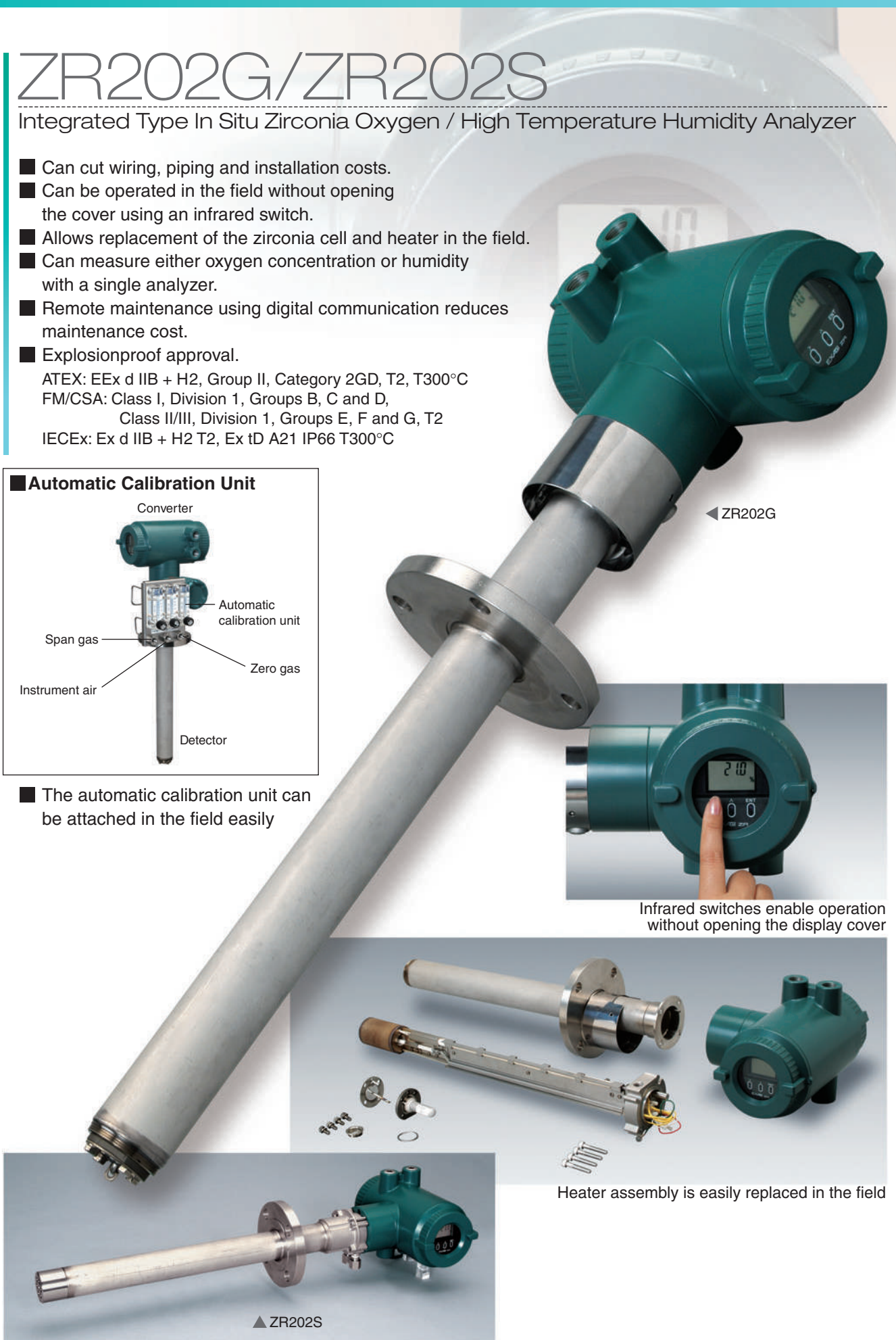

Infrared switches enable operation without opening the display cover

Heater assembly is easily replaced in the field

ZR402G/ZR22G/ZR22S

Separate Type In Situ Zirconia Oxygen / High Temperature Humidity Analyzer

- Liquid-crystal touch panel display provides easy operation.
- Interactive model displays instructions to follow, including those for: settings, oxygen concentration trends, and calibration operations.
- Digital communications features are provided as standard – this enables the analyzer to be maintenance-serviced remotely.
- Can measure either oxygen concentration or humidity with a single analyzer.
- Highly reliable measurements with trend-data graphs.
- The zirconia cell and heater assembly can be replaced in the field.
- Explosionproof approval.

ATEX: EEx d IIB + H2, Group II, Category 2GD, T2, T300°C
 FM/CSA: Class I, Division 1, Groups B, C and D,
 Class II/III, Division 1, Groups E, F and G, T2
 IECEx: Ex d IIB + H2 T2, Ex tD A21 IP66 T300°C



▲ ZR402G Converter

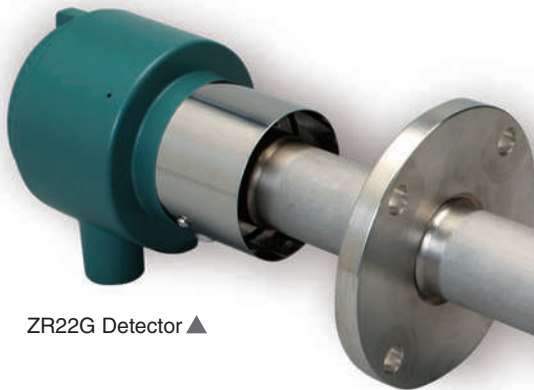

ZR22G Detector ▲

Achieving accurate O₂ measurement in exhaust gas

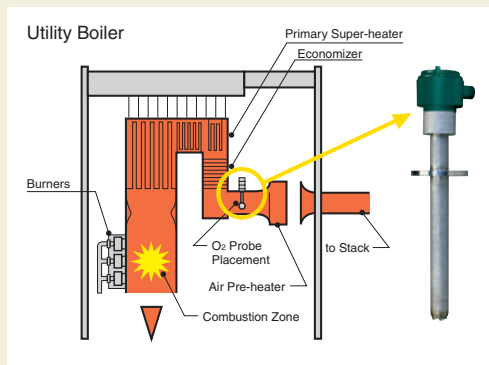

With the measurement of oxygen in the exhaust gas the flow of fuel can be controlled for optimum burner efficiency and minimum environmental effects.

The relationship between air Rates and Heat Efficiency

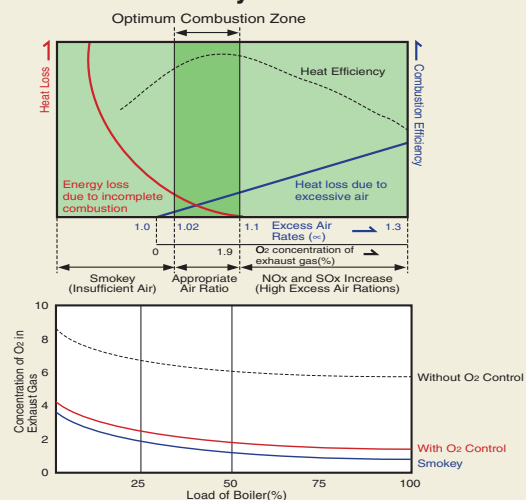

ZR402G Separate Type Converter

Complete Operation Display

- Interactive operations along with operation display.
- A variety of display modes – enabling you to select the operation mode freely.
- Back-lit LCD allows viewing even in the darkness.
- Error codes and details of errors can be checked in the field without the need to refer to the appropriate instruction manual.



Typical Converter Displays

● Example of basic display

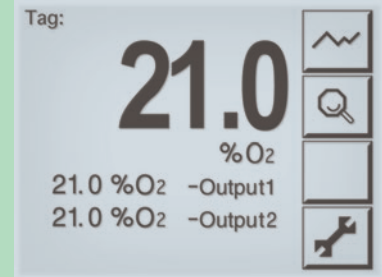

This display enables you to operate the analyzer while checking data on the display.

● Example of trend display – displays data changes

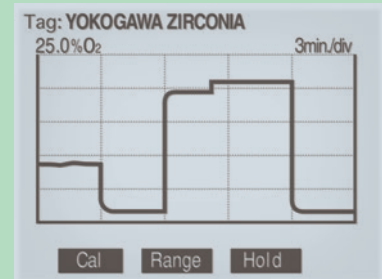

During automatic calibration, you can check stabilized display data while viewing oxygen trend data, thus providing highly reliable calibration.

● Example of setting data display – displays data changes

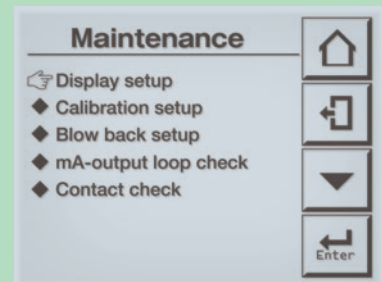

- One-touch interactive display operation
- User-friendly design providing easy operation without having to use the instruction manual.

Self-testing suggests countermeasures for problems

If a problem occurs, the liquid-crystal display will provide an error code and the reason for the problem. This enables prompt and appropriate corrective action to be taken.

Error code	Reason for error
E--1	Cell failure
E--2	Abnormal heater temperature
E--3	Defective A/D converter
E--4	Faulty EEPROM
ALARM1	Abnormal oxygen concentration
ALARM2	Abnormal moisture content
ALARM3	Abnormal mixing ratio
ALARM6	Abnormal zero calibration factor
ALARM7	Abnormal span calibration factor
ALARM8	Stabilization time over

ZR22S Explosionproof version Detector

ZR22S Detector

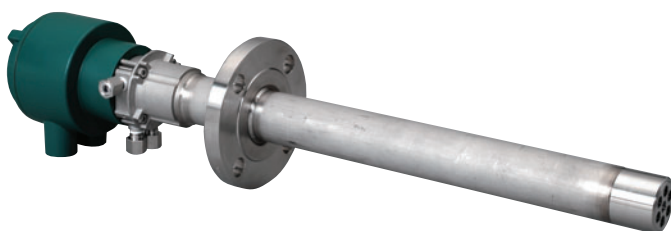

System configuration

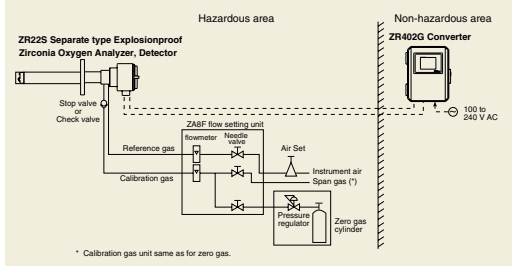

AV550G

Zirconia Oxygen Averaging Converter

The O2mation, model AV550G, averaging converter was designed with a focus on practical performance. Yokogawa has refined its expertise in the combustion oxygen business into this new and creative product. It is packed with features designed to minimize plant down time and technical support for the oxygen measurement. Its intuitive color touch screen operation, powerful new process diagnostic tools and creative hardware design makes power boiler oxygen trim automation simple, predictable and reliable.

- Full color touch screen operation.
- Special trend graph functions with customer graph configuration.
- Multiple display modes shows average data, single detector or all detector gas concentrations.
- Handles input of up to 8 oxygen detectors.
- “Hot swap” of channel cards so the analyzer remains on line while maintenance is performed.
- Eight 4-20 mA outputs for individual detectors.
- Three 4-20 mA outputs for average oxygen concentration outputs.
- Failed, in calibration, or alarming, detectors are automatically excluded from average calculations.
- Allows contact input, calibration activation, range change and detector performance validation.
- Remote maintenance using digital communications (HART or FOUNDATION Fieldbus) reduces maintenance costs.*1

*1:HART is a registered trademark of HART Communication Foundation.

FOUNDATION is a registered trademark of Fieldbus foundation.



▲ AV550G Averaging Converter

Combustion control by a multiple point oxygen measurement

A multiple point oxygen measurement system is required for situations when gas stratification in the flue duct affects combustion control. The AV550G Averaging Converter can accept inputs from up to eight zirconia oxygen detectors. It sends output signals for the individual as well as averages of multiple oxygen concentrations. A robust multipoint converter reduces installation and maintenance costs.

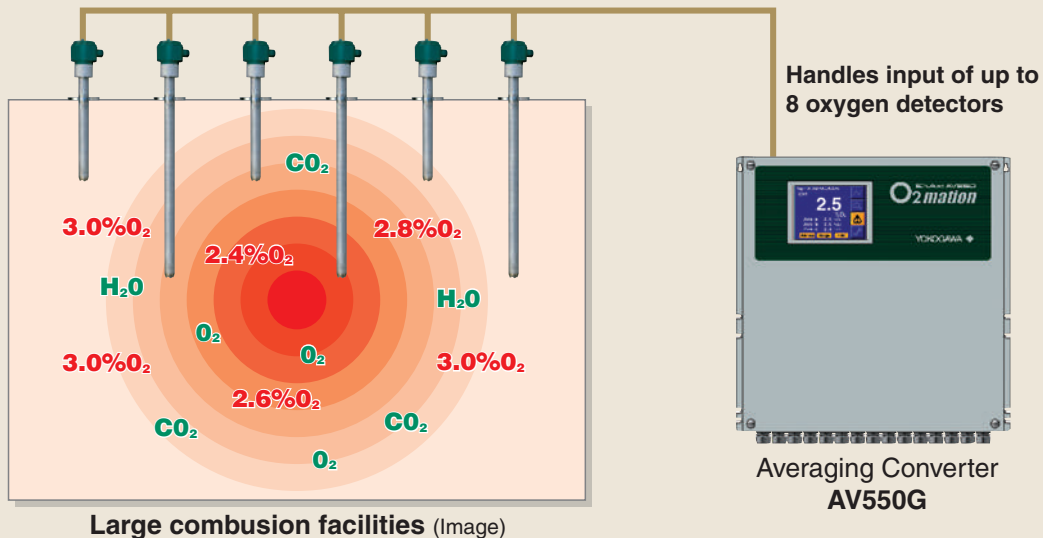

AV550G Averaging Converter

Complete Operation Display

- A large 5.7-inch color touch screen operation.
- The trend graph of max 8 channels helps diagnose problems and view individual detector performance over time.
- Error codes and details of errors can be checked in the field without the need to refer to the appropriate instruction manual.

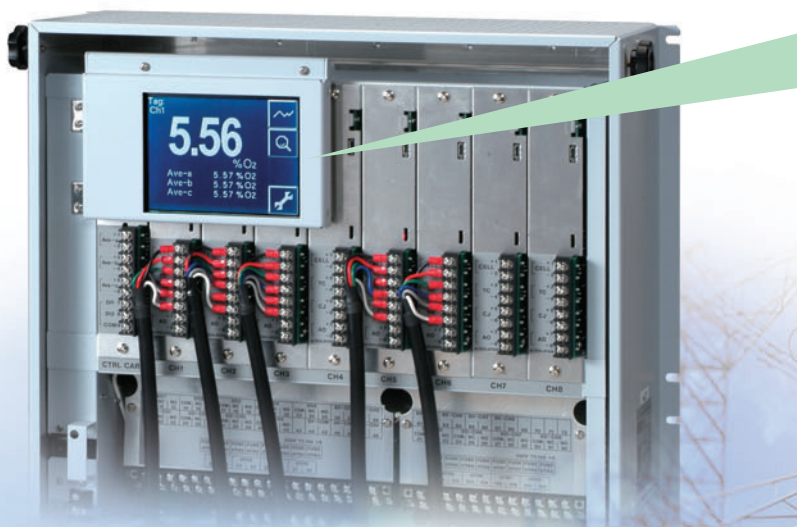

Easy Maintenance and Inspection

Maintenance and inspection are simplified by a modular hardware design. The **Hot Swap** feature allows changing channel modules without powering off the analyzer. Each channel card is fitted with spacious, and accessible, self-trapping terminal strips that make wiring and maintenance fast and easy.

Applications

Utility Boiler – With large boilers used in the utility industry, the oxygen concentration varies in different zones across the flue. In order to obtain the most reliable oxygen data, the most common method used is the averaging of several measuring points using an external averaging unit. The AV550G not only averages the signals but fully controls all of the individual detectors thereby eliminating the need for costly, redundant hardware or DCS programming.

Process Heater – Process industries, such as refining, use large numbers of individual oxygen analyzers to maximize the combustion efficiency of process heaters. The AV550G receives and controls inputs from oxygen detectors mounted on the same or multiple flues and transmits either individual or averaged output signals.

Typical Converter Displays

● Example of basic display



This display enables you to operate the analyzer while checking data on the display.

● Example of trend display

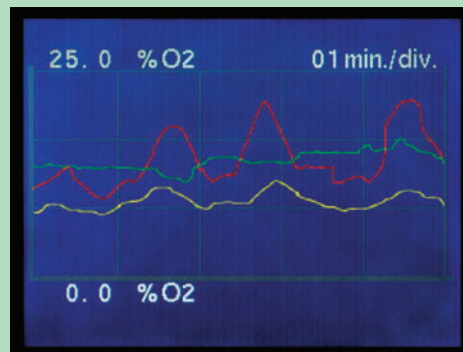

● Example of 8 channel data display



Easy Maintenance and Inspection

Application and System Configuration

The basic configuration consists of a probe and a converter. A flow unit and calibration cylinder may be added as required, depending on the application requirements. The optimal probe may be selected from a variety of probes. One type of converter is capable of handling all applications.

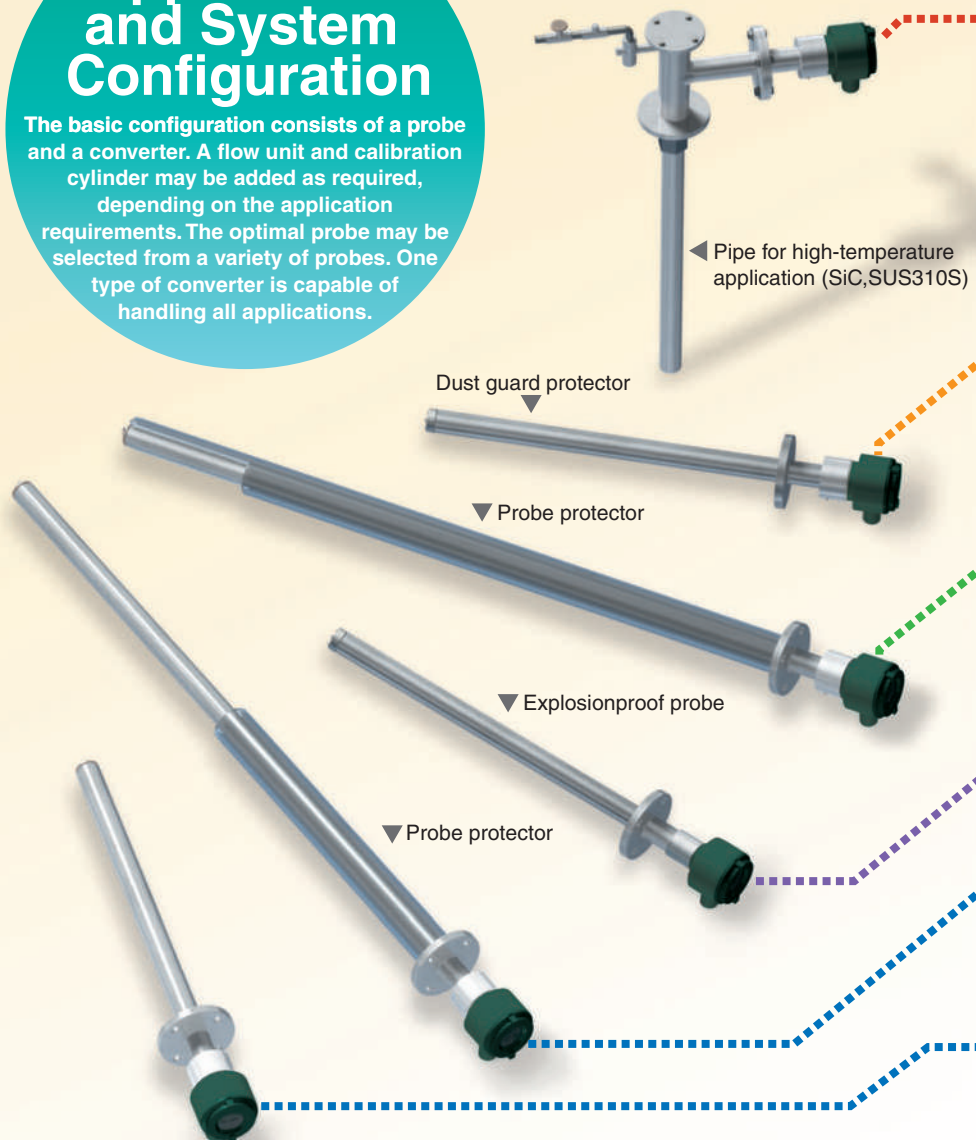

Detector

High temperature probe (0 to 1400°C)
For sample gas temperature over 700°C

General purpose probe + Dust guard protector
Protects probe against dust

General purpose probe + probe protector
Protectors prevent the probe from being eroded by fine particles

Explosion proof probe

General purpose probe + probe supporter
Protectors allow the probe to be installed horizontally

General purpose probe (0 to 700°C)
Various insertion lengths are available: 0.4, 0.7, 1.0, 1.5, 2.0, 2.5 and 3.0 meters

Application

Boiler (fuel oil and gas)	Common
Boiler (coal)(pulverized coal on fluidized bed)	
Boiler (bark or wood chips)	
Heating furnace	Iron & steel
Soaking pit	
Annealing furnace	
Hot stove	
Coke oven	Non-ferrous metals
Sintering furnace	
Melting furnace	
Heating and annealing furnaces	Ceramics
Lime kiln (rotary)	
Lime kiln (vertical)	
Cement kiln (cyclone exit)	
Glass melting furnace (in furnace)	
Glass melting furnace (in stack)	
Ceramic baking furnace	
Heating furnace	Petroleum
Naphtha cracking furnace	Petrochemical
Heating furnace	
Black liquor recovery boiler	Pulp & paper
Sludge kiln/boiler	Machinery
Forging furnace	
Heat treatment furnace	Electric power
Window box	
Drying furnace	
Reaction furnace	
Roasting furnace	
Incinerator	
Sludge burning furnace	
Fermentation tank	
Indoor oxygen-deficiency monitoring	

Signal line/heater line
Special cables not required. General-purpose shielded cables can be used. The distance between the probe and converter can be approximately 500 m if a 2 mm² cable is used and approximately 300 m if a 1.25 mm² cable is used.

Calibration gas line
Check valve installed to prevent a reverse flow of the process gas.

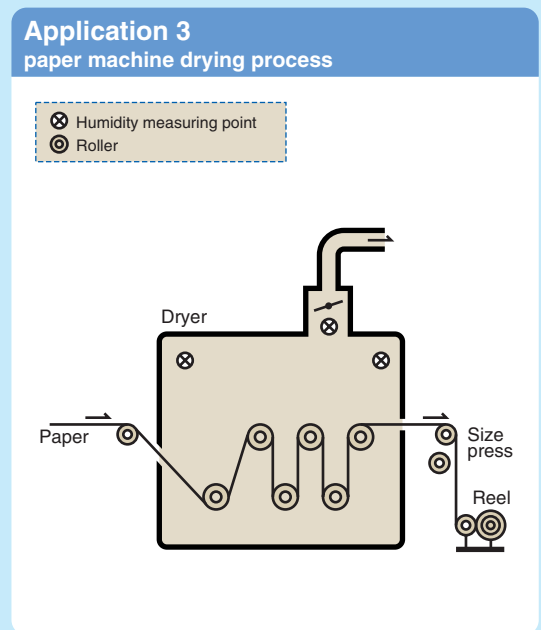
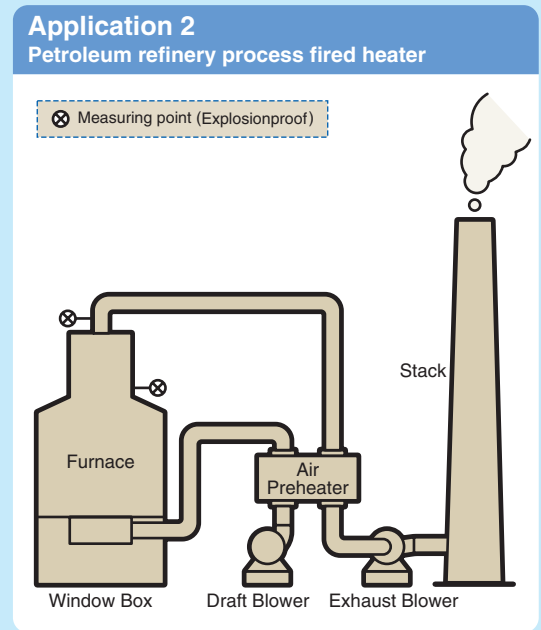
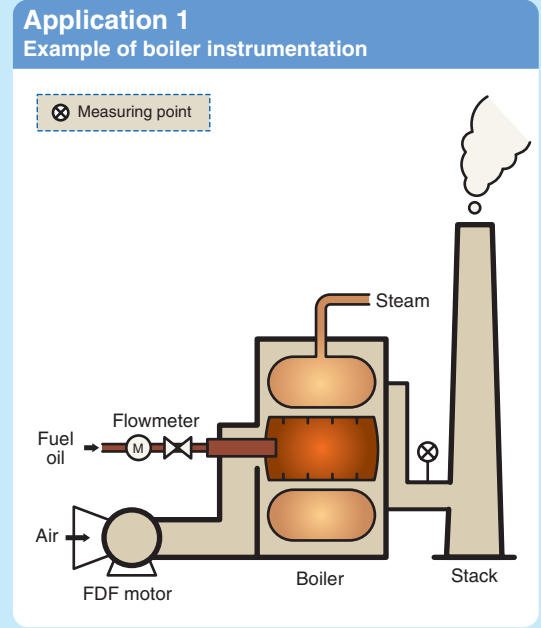
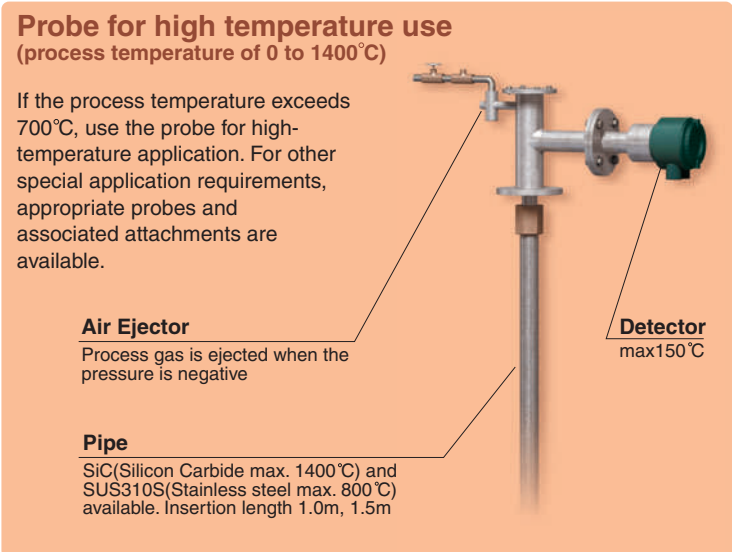
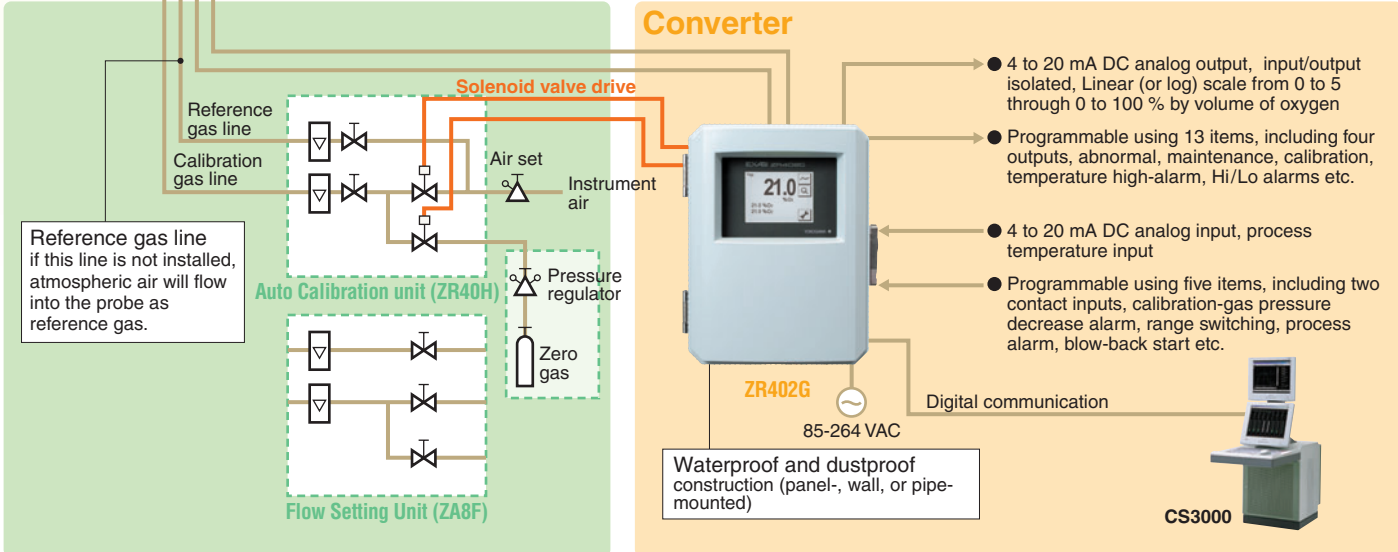

SPECIFICATIONS AND EXTERNAL DIMENSIONS

General purpose version

Model Name	ZR22G/ZR402G, ZR202G
Object of measurement	Oxygen Analyzer: Oxygen concentration in combustion exhaust gas and mixed gases (excluding inflammable gases) Humidity Analyzer: water vapor (in vol%) in mixed gases (air and water vapor) (Only non-explosionproof)
Measurement system	Zirconia
Measuring range	Display O ₂ : 0 to 100 vol% O ₂ (digital display) H ₂ O: 0 to 100 vol% H ₂ O or 0 to 1,000 kg/kg, % relative humidity, dew point Output O ₂ : Any setting in the range from 0 to 5 vol% O ₂ to 0 to 100 vol% O ₂ (1 vol% O ₂ scale) H ₂ O: Any setting in the range from 0 to 25 vol% H ₂ O to 0 to 100 vol% H ₂ O or 0 to 0.200 kg/kg to 0 to 1,000 kg/kg
Process gas pressure	O ₂ : -5 to +250 kpa (Non-explosionproof) H ₂ O: -5 to +20 kpa
Sample gas temperature	General purpose use: 0 to 700 °C High temperature use: 0 to 1400 °C
Insertion length	General purpose use: 0.4, 0.7, 1.0, 1.5, 2.0, 2.5 or 3.0 meters High temperature use: 1.0 or 1.5 meters
Output signal	4 to 20 mA DC analog output and Digital Communication
Contact output Selectable:	(1) Abnormal, (2) High-high alarm, (3) High alarm, (4) Low-low alarm, (5) Low alarm, (6) Maintenance, (7) Calibration, (8) Range switching ZR202G; 2 points ZR402G; 4 points answer-back, (9) Warm-up, (10) Calibration-gas pressure decrease (answer-back of contact input), (11) Temperature high alarm, (12) Blowback start, (13) Flameout gas detection (answerback of contact input)
Alarm Related Items	Oxygen concentration high alarm/ high-high alarm limit values (vol% O ₂), Oxygen concentration low alarm/ low-low alarm limit values (vol% O ₂), Oxygen concentration alarm hysteresis (vol% O ₂), Oxygen concentration alarm detection, alarm delay (seconds)
Self-diagnosis	Abnormal cell, abnormal cell temperature (low/high), abnormal calibration, defective A/D converter, defective digital circuit
Calibration method	Manual, semi-auto or auto-matic calibration
Construction of detector	Waterproof construction, NEMA4X/IP66
Construction of converter	Dustproof and waterproof construction, NEMA4X/IP66
Ambient temperature	ZR22G: -20° to 150 °C; ZR402G: -20 to 55 °C; ZR202G: -20 to 55 °C
Power requirements	85 to 264 V AC, 50/60 Hz

* Refer to the GS11M12A01-01E for detailed specification.

Separate type Zirconia Oxygen / High Temperature Humidity Analyzer, Detector

Model	Suffix code	Option code	Description	
ZR22G	-----	-----	Separate type Zirconia Oxygen/ High Temperature Humidity Analyzer, Detector	
Length	-015	-----	0.15 m (for high temperature use)	
	-040	-----	0.4 m	
	-070	-----	0.7 m	
	-100	-----	1.0 m	
	-150	-----	1.5 m	
	-200	-----	2.0 m	
	-250	-----	2.5 m	
	-300	-----	3.0 m	
	-360	-----	3.6 m	
	-420	-----	4.2 m	
	-480	-----	4.8 m	
	-540	-----	5.4 m	
	Wetted material	-S	-----	SUS316
		-C	-----	Stainless steel with Inconel calibration gas tube
Flange	-A	-----	ANSI Class 150 2 RF SUS304	
	-B	-----	ANSI Class 150 3 RF SUS304	
	-C	-----	ANSI Class 150 4 RF SUS304	
	-E	-----	DIN PN10 DN50 A SUS304	
	-F	-----	DIN PN10 DN80 A SUS304	
	-G	-----	DIN PN10 DN100 A SUS304	
	-K	-----	JIS 5K 65 FF SUS304	
	-L	-----	JIS 10K 65 FF SUS304	
	-M	-----	JIS 10K 80 FF SUS304	
	-P	-----	JIS 10K 100 FF SUS304	
	-Q	-----	JIS 5K 32 FF SUS304 (for high temperature use)	
	-R	-----	JPI Class 150 4 RF SUS304	
	-S	-----	JPI Class 150 3 RF SUS304	
	-W	-----	Westinghouse	
Reference gas	-C	-----	Natural convection	
	-E	-----	External connection (Instrument air)	
	-P	-----	Pressure compensated	
Gas Thread	-R	-----	Rc 1/4	
	-T	-----	1/4 FNPT	
Connection box thread	-P	-----	G1/2	
	-G	-----	Pg13.5	
	-M	-----	M20 x1.5 mm	
	-T	-----	1/2NPT	
Instruction manual	-Q	-----	Quick connect	
	-J	-----	Japanese	
	-E	-----	English	
	-C	-----	Chinese	
—	-A	-----	Always -A	
Options	/D	-----	DERAKANE coating	
	/C	-----	Inconel bolt	
	/CV	-----	Check valve	
	/SV	-----	Stop valve	
	/F1	-----	Dust Filter	
	/F2	-----	Dust Guard Protector	
Tag plates	/SCT	-----	Stainless steel tag plate	
	/PT	-----	Printed tag plate	

Integrated type Zirconia Oxygen / High temperature Humidity Analyzer

Model	Suffix code	Option code	Description
ZR202G	-----	-----	Integrated type Zirconia Oxygen/ High Temperature Humidity Analyzer
Length	-040	-----	0.4 m
	-070	-----	0.7 m
	-100	-----	1.0 m
	-150	-----	1.5 m
	-200	-----	2.0 m
	-250	-----	2.5 m
	-300	-----	3.0 m
	Wetted material	-S	-----
-C		-----	Stainless steel with Inconel calibration gas tube
Flange	-A	-----	ANSI Class 150 2 RF SUS304
	-B	-----	ANSI Class 150 3 RF SUS304
	-C	-----	ANSI Class 150 4 RF SUS304
	-E	-----	DIN PN10 DN50 A SUS304
	-F	-----	DIN PN10 DN80 A SUS304
	-G	-----	DIN PN10 DN100 A SUS304
	-K	-----	JIS 5K 65 FF SUS304
	-L	-----	JIS 10K 65 FF SUS304
	-M	-----	JIS 10K 80 FF SUS304
	-P	-----	JIS 10K 100 FF SUS304
	-R	-----	JPI Class 150 4 RF SUS304
-S	-----	JPI Class 150 3 RF SUS304	
-W	-----	Westinghouse	
Auto Calibration	-N	-----	Not required
	-A	-----	Horizontal mounting
	-B	-----	Vertical mounting
Reference gas	-C	-----	Natural convection
	-E	-----	External connection (Instrument air)
	-P	-----	Pressure compensated
Gas Thread	-R	-----	Rc 1/4
	-T	-----	1/4 FNPT
Connection box thread	-P	-----	G1/2
	-G	-----	Pg13.5
	-M	-----	M20x1.5 mm
	-T	-----	1/2NPT
Instruction manual	-J	-----	Japanese
	-E	-----	English
	-C	-----	Chinese
—	-A	-----	Always -A
Options	/D	-----	DERAKANE coating
	/C	-----	Inconel bolt
	/HS	-----	Set for Humidity Analyzer
	/CV	-----	Check valve
	/SV	-----	Stop valve
	/H	-----	Hood
	/F1	-----	Dust Filter
	/F2	-----	Dust Guard Protector
	/SCT	-----	Stainless steel tag plate
	/PT	-----	Printed tag
NAMUR NE43 compliant	/C2	-----	Failure alarm down-scale: Output status at CPU failure and hardware error is 3.6 mA or less
	/C3	-----	Failure alarm up-scale: Output status at CPU failure and hardware error is 21.0 mA or more

SPECIFICATIONS AND DIMENSIONS

Explosionproof version

Model Name	ZR22S, ZR202S
Object of measurement	Oxygen Analyzer: Oxygen concentration in combustion exhaust gas and mixed gases (excluding inflammable gases)
Measuring range	Display O ₂ : 0 to 100 vol% O ₂ (digital display) Output O ₂ : Any setting in the range from 0 to 5 vol% O ₂ to 0 to 100 vol% O ₂ (1 vol% O ₂ scale)
Process gas pressure	-5 to +5 kpa
Insertion length	General purpose use: 0.4, 0.7, 1.0, 1.5 or 2.0 meters High temperature use: 1.0 or 1.5 meters
Explosionproof Approval	ATEX: EEx d IIB + H ₂ , Group II, Category 2GD, T2, T300°C FM/CSA: Class I, Division 1, Groups B, C and D, Class II/III, Division 1, Groups E, F and G, T2 IECEX: Ex d IIB + H ₂ T2, Ex tD A21 IP66 T300 °C
Ambient temperature	ZR22S: -20 to 60 °C (-20 to 150 °C on the terminal box surface); ZR402G: -20 to 55 °C ZR202S: -20 to 55 °C
Wiring Connection	ATEX: M20 by 1.5 mm or 1/2 NPT select one type FM: 1/2 NPT CSA: 1/2 NPT IECEX: M20 by 1.5 mm or 1/2 NPT select one type

Characteristics

Repeatability	O ₂ : ± 0.5 % Maximum value of setting range H ₂ O: ± 1% Maximum value of setting range
Drift	O ₂ : ± 2 % Maximum value of setted range/month H ₂ O: ± 3% Maximum value of setted range/month
Response speed	90 % response within 5 sec. (after gas is introduced from calibration gas inlet)

* Refer to the GS11M13A01-01E for detailed specification.

Separate type Explosionproof Zirconia Oxygen Analyzer, Detector

Model	Suffix code	Option code	Description
ZR22S	-----	----	Separate type Explosionproof Zirconia Oxygen Analyzer, Detector
Explosion proof Approval	-A -B -C -D	----	ATEX certified flameproof FM certified explosionproof CSA certified explosionproof IECEX certified flameproof
Length	-015 -040 -070 -100 -150 -200	----	0.15 m (for high temperature use) 0.4 m 0.7 m 1.0 m 1.5 m 2.0 m
Wetted material	-S -C	----	SUS316 Stainless steel with Inconel calibration gas tube
Flange	-A -B -C -E -F -G -Q -W	----	ANSI Class 150 2 RF SUS304 ANSI Class 150 3 RF SUS304 ANSI Class 150 4 RF SUS304 DIN PN10 DN50 A SUS304 DIN PN10 DN80 A SUS304 DIN PN10 DN100 A SUS304 JIS 5K 32 FF SUS304 (for high temperature use) Westinghouse
Reference gas	-E	----	External connection (Instrument air)
Gas Thread	-R -T	----	Rc 1/4 1/4 NPT
Connection box thread	-M -T	----	M20 x 1.5 mm 1/2 NPT
Instruction manual	-E	----	English
Options	-A	----	Always -A
Valves	/C /CV /SV	----	Inconel bolt Check valve Stop valve
Tag plates	/SCT /PT /FT	----	Stainless steel tag plate Printed tag plate

Integrated type Explosionproof Zirconia Oxygen Analyzer

Model	Suffix code	Option code	Description
ZR202S	-----	----	Integrated type Explosionproof Zirconia Oxygen Analyzer
Explosion proof Approval	-A -B -C -D	----	ATEX certified flameproof FM certified explosionproof CSA certified explosionproof IECEX certified flameproof
Length	-040 -070 -100 -150 -200	----	0.4 m 0.7 m 1.0 m 1.5 m 2.0 m
Wetted material	-S -C	----	SUS316 Stainless steel with Inconel calibration gas tube
Flange	-A -B -C -E -F -G -W	----	ANSI Class 150 2 RF SUS304 ANSI Class 150 3 RF SUS304 ANSI Class 150 4 RF SUS304 DIN PN10 DN50 A SUS304 DIN PN10 DN80 A SUS304 DIN PN10 DN100 A SUS304 Westinghouse
Auto Calibration	-N -A -B	----	Not required Horizontal mounting Vertical mounting
Reference gas	-E	----	External connection (Instrument air)
Gas Thread	-R -T	----	Rc 1/4 1/4 NPT(F)
Connection box thread	-M -T	----	M20 x 1.5 mm 1/2 NPT
Instruction manual	-E	----	English
Options	-A	----	Always -A
Valves	/C /CV /SV	----	Inconel bolt Check valve Stop valve
Tag plates	/H /SCT /PT /C2	----	Hood Stainless steel tag plate Printed tag plate Failure alarm down-scale: Output status at CPU failure and hardware error is 3.6 mA or less Failure alarm up-scale: Output status at CPU failure and hardware error is 21.0 mA or more
NAMUR NE43 compliant	/C3	----	

Separate Type Explosionproof Detector ZR22S

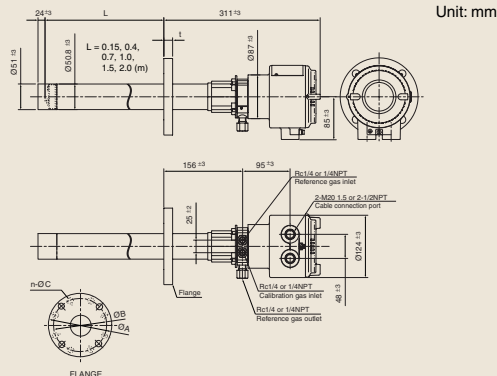

Integrated Type Explosionproof Analyzer ZR202S

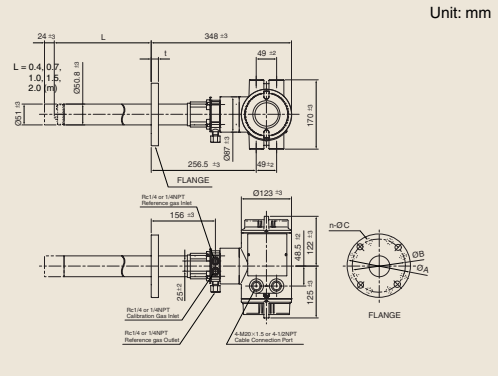

SPECIFICATIONS AND EXTERNAL DIMENSIONS

Standard Specification

Model name	AV550G
Object of measurement	Oxygen in combustion exhaust gas or non-flammable gas mixtures
Measurement system	Zirconia type
Measurement range	Display: 0 to 100% (3-digit display) Output: Any setting in the range from 0 to 5 vol% O ₂ to 0 to 100 vol% O ₂
Number of detectors	1 to 8
Detector Compatibility	ZR22G, ZR22S, ZO21D, ZO21DW
Power Supply	86 to 126.5 VAC, 50/60 Hz
Power Consumption	100 V type : Max: 40 W + (120 W) (Number of detectors) for steady operation, Max: 40 W + (220 W) (Number of detectors) for warm-up. 200 V type : Max: 40 W + (140 W) (Number of detectors) for steady operation, Max: 40 W + (220 W) (Number of detectors) for warm-up.
Display	5.7 inch full color display, 320 × 240 touch screen
Analog output signal	(Average value outputs, individual channel outputs) Range: Settable in the range from 0 to 5% to 0 to 100% O ₂ 4 to 20 mA DC input/output isolated
Contact output signals	5 points, contact rating 30 VDC 3A, 250 VAC 3A (resistive load) Normally energized or de-energized, selectable
Self-diagnostics	Cell, temperature, analog circuit, digital circuit, calibration, ROM/RAM error power loss
Calibration function	One-touch calibration, automatic calibration
Construction	Indoor installation
Ambient Temperature	-5 to + 50 °C

Characteristics

Repeatability:	±0.5% F.S.
Linearity:	±1% F.S. (less than 0 to 25% range)
Drift:	±2% F.S./month for both zero and span
Response:	5 sec maximum for 90% response

*Refer to the GS11M12D01-01E for detailed specification.

Averaging Converter

Model	Suffix Code	Option Code	Specification
AV550G			Averaging Converter
Base	-A		4 Channel Base
	-B		8 Channel Base
Number of Channel Card	-A1		1 Oxygen Channel Card, Common Isolation
	-A2		2 Oxygen Channel Cards, Common Isolation
	-A3		3 Oxygen Channel Cards, Common Isolation
	-A4		4 Oxygen Channel Cards, Common Isolation
	-A5		5 Oxygen Channel Cards, Common Isolation
	-A6		6 Oxygen Channel Cards, Common Isolation
	-A7		7 Oxygen Channel Cards, Common Isolation
	-A8		8 Oxygen Channel Cards, Common Isolation
	-B1		1 Oxygen Channel Card, Individual Isolation
-B2		2 Oxygen Channel Cards, Individual Isolation	
-B3		3 Oxygen Channel Cards, Individual Isolation	
-B4		4 Oxygen Channel Cards, Individual Isolation	
-B5		5 Oxygen Channel Cards, Individual Isolation	
-B6		6 Oxygen Channel Cards, Individual Isolation	
-B7		7 Oxygen Channel Cards, Individual Isolation	
-B8		8 Oxygen Channel Cards, Individual Isolation	
Display	-J		Japanese
	-E		English
	-F		French
	-G		German
Power supply	-1		100 / 115 V AC
	-2		230 V AC
Communication	-E		HART communication
	-F		FOUNDATION Fieldbus communication
Options	/SCT		Stainless steel tag plate
	/24		24 Voltage output for Solenoid valve
	/G □□		Cable gland (Numbers in □□)

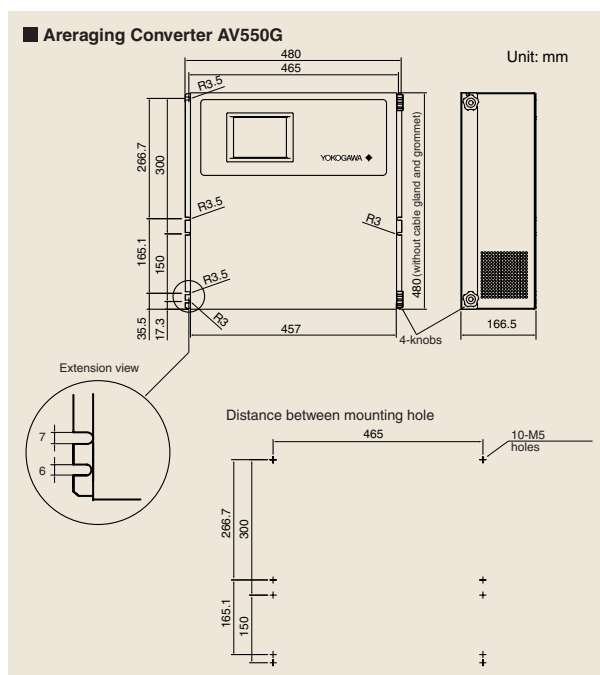

Separate type Zirconia Oxygen / High Temperature Humidity Analyzer, Converter

Model	Suffix code	Option code	Description
ZR402G	-----	-----	Separate type Zirconia Oxygen/ High Temperature Humidity Analyzer, Converter
Converter thread	-P	-----	G1/2
	-G	-----	Pg13.5
	-M	-----	M20x1.5 mm
	-T	-----	1/2NPT
Display	-J	-----	Japanese
	-E	-----	English
	-G	-----	German
	-F	-----	French
Instruction manual	-J	-----	Japanese
	-E	-----	English
	-C	-----	Chinese
—	-A	-----	Always -A
Options	/HS	-----	Set for Humidity Analyzer
	/H	-----	Hood
	/SCT	-----	Stainless steel tag plate
	/PT	-----	Printed tag plate
	NAMUR NE43 compliant	/C2	-----
	/C3	-----	Failure alarm up-scale: Output status at CPU failure and hardware error is 21.0 mA or more

Separate Type General purpose Detector ZR22G

Unit: mm

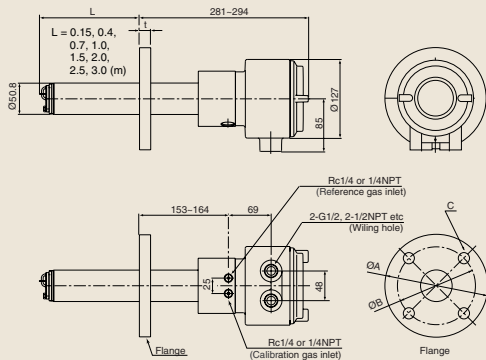

Separate Type General purpose Converter ZR402G

Unit: mm

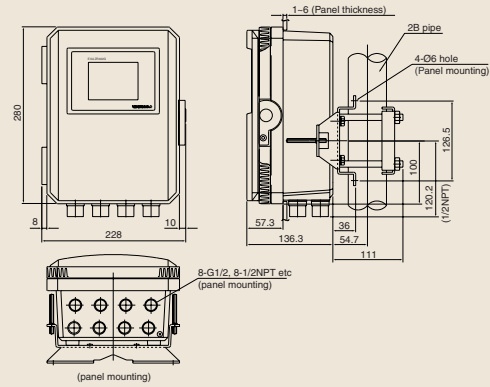

Integrated Type General purpose Analyzer ZR202G

Unit: mm

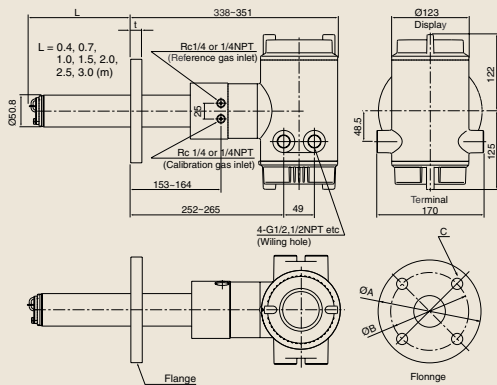

vigilantplant.[®]

The clear path to operational excellence

SEE
CLEARLY

KNOW
IN ADVANCE

ACT
WITH AGILITY

VigilantPlant is Yokogawa's automation concept for safe, reliable, and profitable plant operations. VigilantPlant aims to enable an ongoing state of Operational Excellence where plant personnel are watchful and attentive, well-informed, and ready to take actions that optimize plant and business performance.

YOKOGAWA ELECTRIC CORPORATION

World Headquarters
9-32 Nakacho 2-chome, Musashino-shi,
Tokyo 180-8750, JAPAN
Tel: +81-422-52-6316 Fax: +81-422-52-6619
<http://www.yokogawa.com/an/>

North America
YOKOGAWA CORPORATION OF AMERICA
Georgia, U.S.A
<http://www.yokogawa.com/us/>

South America
YOKOGAWA AMERICA DO SUL LTDA.
BRAZIL
<http://www.yokogawa.com.br/>

Europe
YOKOGAWA EUROPE B.V.
European Headquarters
THE NETHERLANDS
<http://www.yokogawa.com/eu/>
YOKOGAWA ELECTRIC CIS LTD.
RUSSIAN FEDERATION
<http://www.yokogawa.ru/>

Middle East
YOKOGAWA MIDDLE EAST B.S.C.(C)
<http://www.yokogawa.com/bh/>

Singapore
YOKOGAWA ENGINEERING ASIA PTE.LTD.
<http://www.yokogawa.com/sg/>

Korea
YOKOGAWA ELECTRIC KOREA CO., LTD.
<http://www.yokogawa.com/kr/>

China
YOKOGAWA CHINA CO., LTD.
<http://www.yokogawa.com/cn/>
YOKOGAWA SHANGHAI INSTRUMENTATION CO., LTD.
<http://www.ysi.com.cn/>
YOKOGAWA SICHUAN INSTRUMENT CO., LTD.
<http://www.cys.com.cn/>

Taiwan
YOKOGAWA TAIWAN CORPORATION
<http://www.yokogawa.com.tw/>

India
YOKOGAWA INDIA LTD.
<http://www.yokogawa.com/in/>

Australia
YOKOGAWA AUSTRALIA PTY. LTD.
<http://www.yokogawa.com/au/>

Represented by:

Vig-PMK-G-NL-10E

Printed in Japan, 703(KP) [Ed : 10/b]