

# **TRIMTECK<sup>®</sup> OpGL™ Globe Control Valve**

**OPTIMUX<sup>®</sup>**

TECHNICAL BROCHURE



## Introduction

The OpGL Globe Control Valve has been engineered to provide superior control and on-off performance while permitting easy, fast, and cost-effective maintenance. Unlike diaphragm-operated, cage-guided control valves, the Piston Cylinder-actuated, top-guided OpGL™ provides stiffness and maintains high positioning accuracy – making for the world’s most rugged, efficient, and accurately responsive control valve.

Sections	Page
OpGL Globe Control Valve Specifications	1
Features & Advantages . . . . .	2
OpTK Piston Cylinder Linear Actuator . . . . .	4
Bonnet Types . . . . .	6
Packing and Guiding . . . . .	7
Gaskets . . . . .	9
Body Styles . . . . .	10
End Connections . . . . .	12
Flow Characteristics . . . . .	13
Trim . . . . .	13
Flow Capacity (C <sub>v</sub> ) Tables . . . . .	17
Overall Dimension & Weight Tables . . . . .	21

## OpGL Globe Control Valve Specifications

**Table1: OpGL Globe Control Valve Specifications**

Table1: OpGL Globe Control Valve Specifications	
<b>Type</b>	Globe Valve, Sliding Stem
<b>Sizes (NPS)</b>	½” to 24”
<b>Body Styles</b>	Globe, Angle, 3-Way, Y-Pattern, Vacuum Jacketed, Steam Jacketed, Fabricated (XT)
<b>Body Materials</b>	Carbon Steel, Stainless Steel, Chrome Moly, Alloy, Others
<b>Pressure Classes (ASME/ANSI)</b>	CL150 to CL4500
<b>Shutoff Classes (ANSI)</b>	Class IV, V, VI
<b>End Connections</b>	RF Integral Flange, NPT, RTJ, Buttweld, Socketweld, Grayloc, SAE AS5202, Others
<b>Service</b>	General, Special (Low Flow, Corrosive, Erosive, Dirty, Zero Fugitive Emissions), Severe (Cavitation, Noise, Flashing)
<b>Operating Temperature</b>	Standard, High, Cryogenic
<b>Flow Characteristics</b>	Equal Percent, Linear, Bi-Linear, Quick Open, Custom
<b>Industries</b>	Power, Aerospace & Defense, Oil & Gas, Chemical/Petrochemical, Industrial Gases, Refining, Food & Beverage, Metals & Mining, Pulp & Paper
<b>Certifications/Norms</b>	ASME, PED, ANSI/ISA, CRN, NACE

# OpGL™

## Globe Control Valve

### Features & Advantages

**Precise Control** – Broad range of control through a top-guided, unbalanced, single-piece plug with flow characterization built in to the geometry of the plug head.

**Exceptional Shutoff Standard** – ANSI Class V metal-to-metal shutoff in process achieved with unique plug and seat ring design. ANSI Class VI available in soft seated configuration.

**High Thrust Fast-Acting Piston Actuator** – More accurate and quicker than diaphragm actuators, and offering a smaller and lighter footprint – ideal for skid-mounted process equipment.

**Maintainability** – Top-entry design facilitates maintenance, even though the valve has a much longer MTBS Cycle than competing diaphragm-actuated valves.

**Range of Trim Configurations** – From micro-flows to full capacity trims, and everything in between, the OpGL can be sized to optimally control according to your specific process parameters. A full line of anti-cavitation and noise abatement trims available.

<b>OPTIMUX OpGL</b>		
SIZE _____	CLASS _____	BODY _____
TRIM _____	CV _____	CHAR. _____
ACTUATOR _____	AIR TO _____	
SIGNAL _____	S/N _____	
TAG _____		

Figure 1: OpGL Stainless Steel Nameplate

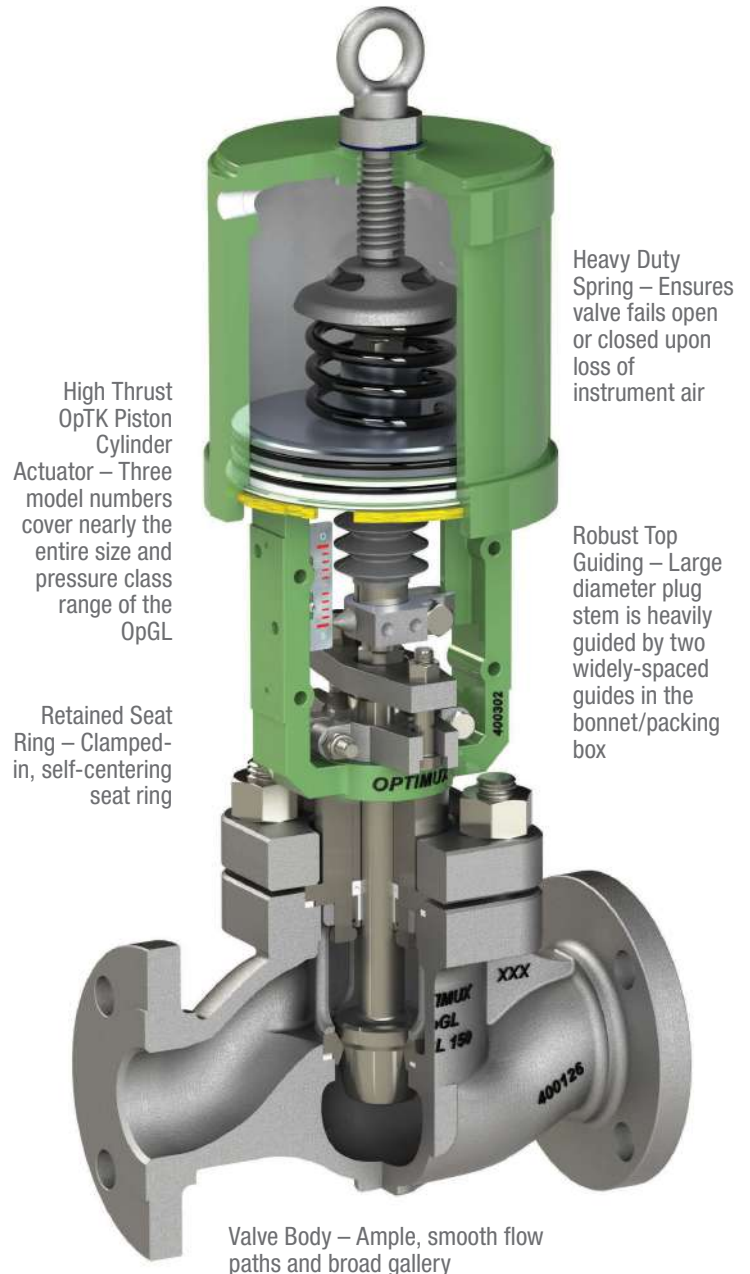
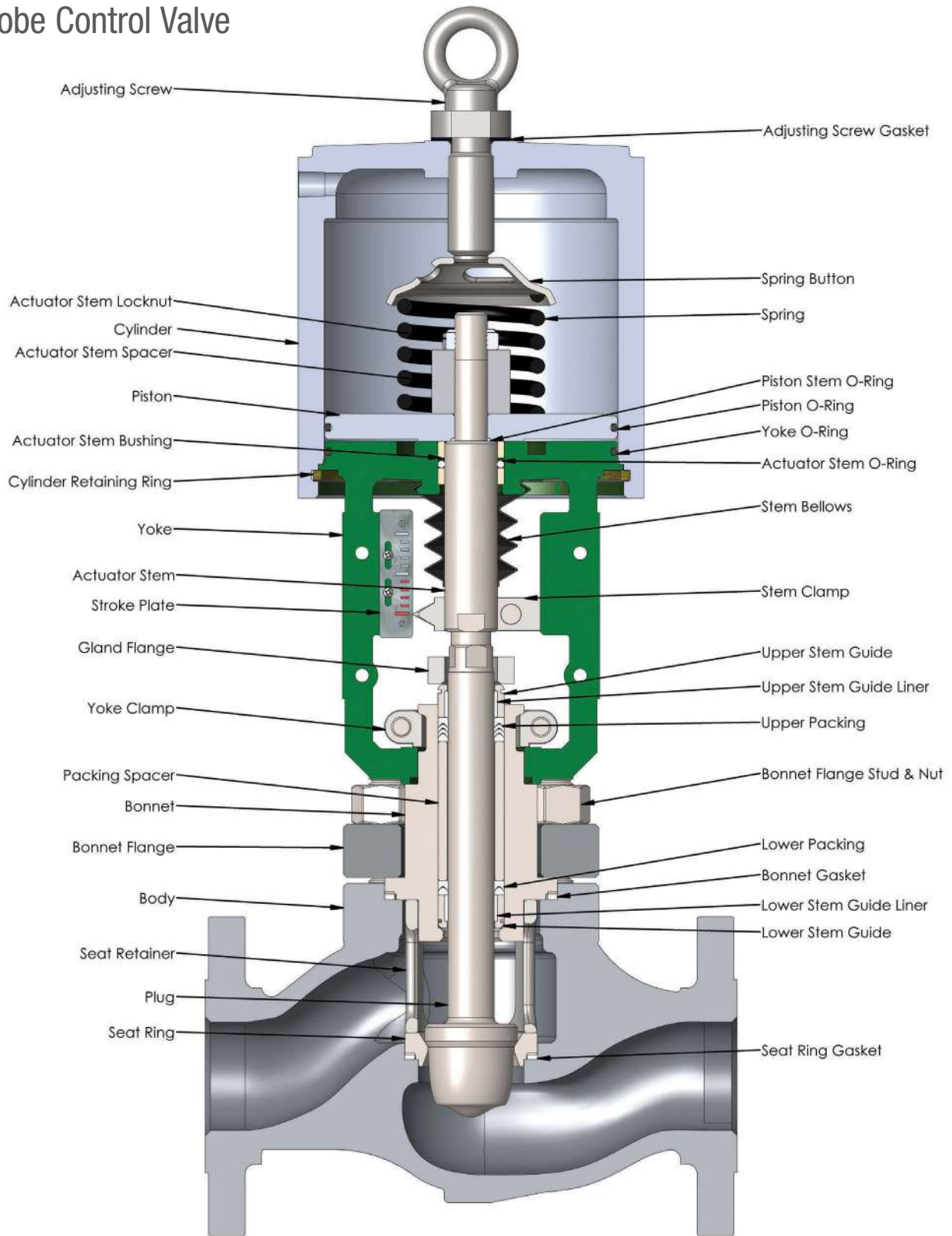


Figure 2: OpGL Globe Control Valve

# OpGL™ Globe Control Valve



**Figure 3: OpGL Globe Control Valve Component List**

## OpGL™

### Globe Control Valve

## OpTK™ Pneumatic Piston Cylinder Linear Actuator



**Figure 4: OpTK Piston-Cylinder Actuator**

The Optimux OpTK Piston-Cylinder Linear Actuator is a powerful, high-performance pneumatic actuator that provides positive throttling or on-off operation for automatic control valves and is a key element of the OpGL Globe Control Valve’s performance and shutoff characteristics. The cylinders are double acting and designed for instrument air supply pressures of up to 150 psi (10.3 Bar) – allowing the OpTK to generate substantial thrust from a compact footprint.

This actuator is fully field reversible for air-to-open or air-to-close action without requiring additional parts; a spring provides fail-safe operation. The positioner supplies air to both sides of the piston, providing exceptionally stiff, precise movement together with very high frequency response.

**Table 2: OpTK Piston Cylinder Actuator Specifications**

<b>Actuator Type</b>	Pneumatic Piston-Cylinder
<b>Motion</b>	Linear
<b>Base Valve Type</b>	Globe, Angle, 3-Way, Custom Engineered/Specialty
<b>Air Supply (PSI)</b>	30 to 150
<b>Piston Size (in<sup>2</sup>)</b>	25, 50, 100, 200, 300
<b>Failure Position</b>	Air-to-Open, Air-to-Close, Fail-Last
<b>Stroking Speed</b>	Less than 1 Second
<b>Ambient Temperature Ranges (F)</b>	-40° to 350° Note: For temperatures above 180F, Viton O-Rings are required. For temperatures below -40 Fluoro-Silicon O-Rings are required.
<b>Options</b>	Side-Mounted Hand Wheel, Top-Mounted Hand Wheel, Limit Stop, Lever Arm
<b>Positioner Mounting</b>	Trimteck HPP Series®, ABB®, Siemens®, Emerson®

**Table 3: OpTK Piston Cylinder Actuator Standard Materials of Construction**

<b>Yoke</b>	A216 WCB Carbon Steel A351 CF8M Stainless Steel
<b>Cylinder</b>	A356 Gr T6 Aluminum A351 CF8M Stainless Steel
<b>Piston</b>	6061 T6 Aluminum Alloy
<b>Spring Button</b>	A351 CF8M Stainless Steel
<b>Adjusting Screw</b>	A351 CF8M Stainless Steel
<b>Stem</b>	F316 Stainless Steel
<b>Spring</b>	Alloy
<b>Retaining Ring</b>	Zinc Plated Alloy

### OpTK™ Features and Advantages

**High thrust** – 150 psi (10.3 Bar) operating pressure allows substantially higher thrust than comparable diaphragm actuators, which provides tighter valve shutoff.

**High frequency** - double-acting configuration responds quickly to signal changes response

**Compact substantially** – lighter and more compact than comparable linear diaphragm actuators, for a smaller overall valve footprint and easier installation and maintenance.

**Versatile** - standard actuator sizes 25, 50 and 100 will handle thrust requirements for over 95% of process applications. Larger sizes are available for special applications.

**Fewer parts** - 1/3 fewer parts than diaphragm linear actuators. Wear parts cost 1/10 of those for diaphragms, and less inventory is required to maintain actuators.

**Dynamic positioning** – supply pressure is sent to both sides of the piston for stiff, precise operation. Air volume between the piston and the bottom of the cylinder provides powerful pneumatic stiffness, allowing a high pressure drop – without plug slamming.

Field reversible failure mode is easily reversed without additional parts.

**Fail-safe spring** – internal spring provides fail-safe operation in the event of air system failure. Universal spring bench set is not required.

**Stiff operation** – supply pressure is sent to both sides of piston for stiff and precise actuator operation without hunting hysteresis.

**Durable components** – high quality materials require very little maintenance, no diaphragm to rupture.

**Simple maintenance** – periodic maintenance is easy to perform, since the spring cylinder actuator only requires the removal of two parts to access all internal parts.

**Low air consumption** – cylinder design uses less supply air than comparable diaphragm actuators.

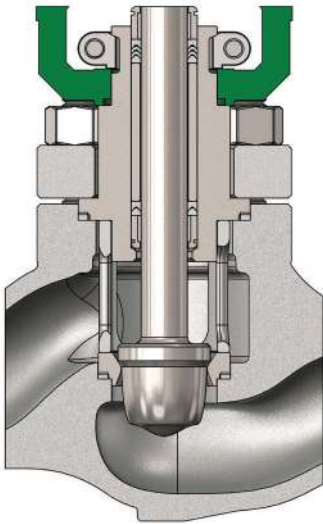
**Longer strokes** – Size 25 spring cylinder linear actuator has a 1 1/2 -inch (38 mm) stroke, in contrast to a 3/4 -inch (19 mm) stroke on a comparable linear diaphragm actuator. Larger actuators have similar comparisons. Stroke lengths are available up to 24-inches.

# OpGL™

## Globe Control Valve

### Bonnet Types

**Standard Bonnet** – The OpGL’s standard bonnet is constructed of the same material as the body for general service applications. Bonnet material selection is dependent on process media and pressure.



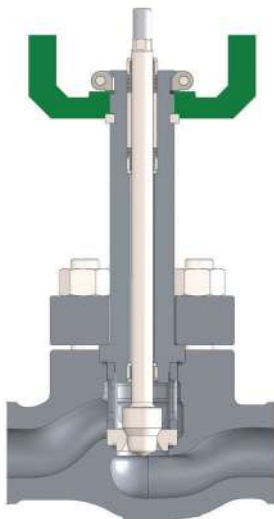
**Figure 5: Standard Bonnet**

**Cryogenic Bonnet** – Trimteck’s cryogenic bonnet features a chamber that fills with the gasified process fluid to form a thermal barrier to protect the packing from the low process temperatures.



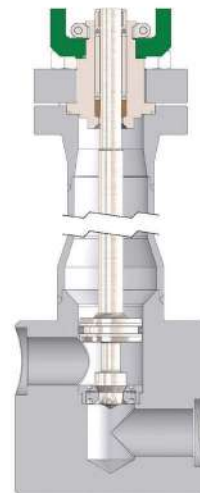
**Figure 7: Cryogenic Bonnet**

**Extended Bonnet** – The extended bonnet is designed to protect the packing and top works of the valve from high process temperatures.



**Figure 6: Extended Bonnet**

**Cold Box Bonnet** – Typically used for valves that will be installed inside of a cold box and require the ability to be serviced from the exterior of the box.

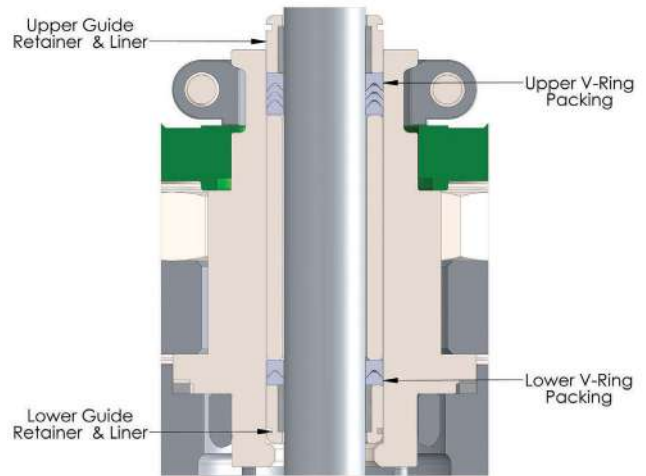


**Figure 8: Cold Box Bonnet**

## Packing & Guiding

The OpGL's bonnet provides a far larger and deeper packing box than most control valves on the market, which allows for the following:

- The ability to install a wide range of packing configurations – including those designed to minimize or eliminate fugitive emissions in compliance with the latest international standards – without changing the bonnet.
- Available in Live-Loaded Configuration.
- Lower packing set functions as a wiper ring that cleans the process fluid off of the plug as it is retracted – and prevents contaminants from reaching the top packing stage.
- Guides are widely spaced and firmly hold the oversized plug stem in place over the course of the stroke.



**Figure 9: Standard Packing Box**

Table 4: Guide Materials					
Standard Material	Maximum Temperature		Minimum Temperature		Maximum Pressure
	°F	°C	°F	°C	
<b>Grafoil Lined Stainless Steel</b>	1500	816	-320	-196	1000 psig upto 2in. 600 psig 3in/4in. 500 Psig 6in and above
<b>PTFE Glassfilled Lined Stainless Steel</b>	350	177	-50	-45	600 psig @ 150 F
<b>PTFE Virgin Lined Stainless Steel</b>	350	177	-423	-253	100 psig @ 350°F
<b>Solid Bronze</b>	500	260	-423	-253	same as the body
<b>A 479 S21800 Nitronic 60</b>	1500	816	-423	-253	same as the body
<b>Solid Stellite</b>	1500	816	-423	-253	same as the body



**OpGL™**

## Globe Control Valve

### Eliminating Fugitive Emissions

Trimteck's GuardMaster Metal Bellows Seals are designed to protect against atmospheric emissions of caustic gases and liquids as a result of packing leakage.

- High quality, modular construction in Inconel or Hastelloy
- Built to withstand high temperatures and pressures
- Extraordinarily long lifecycle
- Can be retrofitted to valves of all sizes and pressure classes
- Sized and manufactured to specific customer requirements



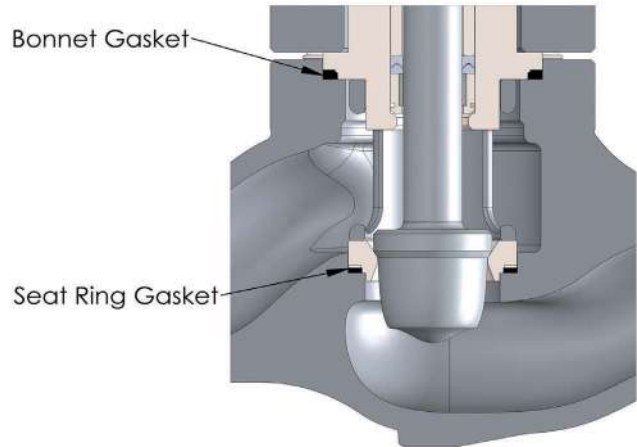
**Figure 10: GuardMaster Metal Bellows Seal**

Table 5: Packing Materials							
	Material	TYPE	Standard Bonnet		Extended Bonnet		Fugitive Emissions Performance
			°F	°C	°F	°C	
<b>Standard Packing</b>	Virgin PTFE	V-Ring	-20 to 450	-28 to 232			Good
	Glass Filled PTFE	V-Ring	-20 to 500	-28 to 260	-150 to 600	-101 to 316	Satisfactory
	Braided PTFE	Square					
	AFPI	Square	-20 to 750	-28 to 398	-20 to 1200	-28 to 649	Good
<b>Fugitive Emissions Packing</b>	PTG (25% Carbon Filled PTFE)	V-Ring Live-Loaded	-20 to 450	-28 to 232	-20 to 600	-28 to 316	Very Good (500 PPM)
	PT (25% Carbon Filled PTFE)	V-Ring	-20 to 450	-28 to 232	-20 to 600	-28 to 316	Excellent (100 PPM)
	PTXT (40% Carbon Fiber PEEK)	V-Ring	-20 to 550	-28 to 288	-20 to 700	-28 to 371	
	GuardMaster MBS	Hydroformed 2-Ply Seamless	-20 to 750	-28 to 398	-20 to 1200	-28 to 649	Zero Emissions

**Note: PTFE can be used in temperatures down to -423° F (-253° C)**

## Gaskets

The OpGL's two most critical soft goods are its bonnet and seat gaskets. The OpGL's body, seat ring, seat retainer, and bonnet are all designed and machined to close tolerances and configured to transfer the force applied to the bonnet bolting down into the seat ring – clamping it securely into the body. As such the gaskets are compressed per their design but never over-compressed because the bonnet and the seat bottom out mechanically.



**Figure 11: OpGL Body Gaskets**

**Table 6: Gasket Materials and Temperature**

ANSI Class	TYPE	Gasket Material	Maximum Gasket Temperature		Minimum Gasket Temperature	
			°F	°C	°F	°C
<b>Standard Gaskets</b>	Flat	Teflon (TFE)	350	177	-200	-130
	Spiral Wound	304 SS / AFG	750	400	-20	-30
	Spiral Wound	316 SS / AFG	100	538	-20	-30
<b>Alternate Gaskets</b>	Flat	AFG	600	318	-20	-30
	Flat	KEL-F	350	177	-423	-253
	Flat	Teflon (FEP)	400	204	-423	-253
	Flat	Grafoil	1500	816	-320	-196
	Spiral Wound	316 SS / Grafoil	1500	816	-320	-196
	Hollow O-Ring	Inconel X-750	1500	816	-20	-30

## OpGL™

### Globe Control Valve

#### Body Styles

**Globe** – This most common single-seated body style forces fluid through two 90-degree turns, allowing for significant pressure drops.

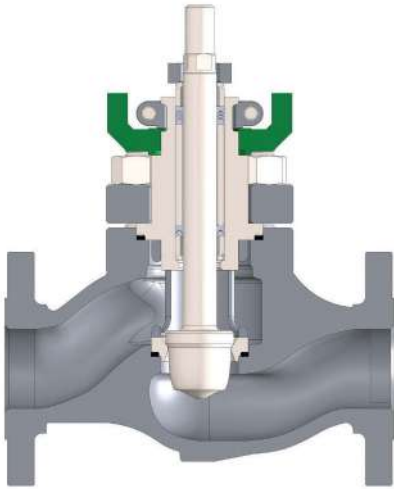


Figure 12: Globe Style Body

**Y-Pattern** – A nearly straight-through flow passage is less restrictive than the standard globe style, which helps to reduce turbulence and vibration in the line.

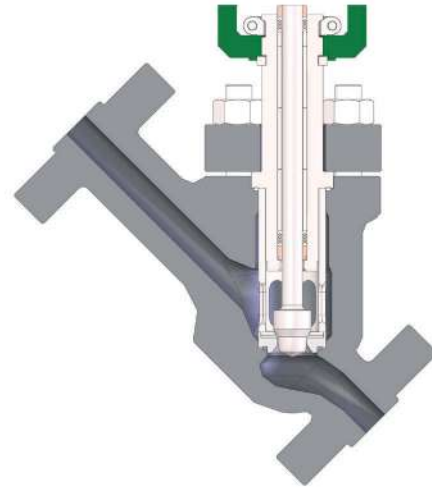


Figure 14: Y-Pattern Body

**Angle** – Body forms a 90-degree angle for cases in which piping allows for only such a configuration, or in cases of severe cavitation and/or flashing.

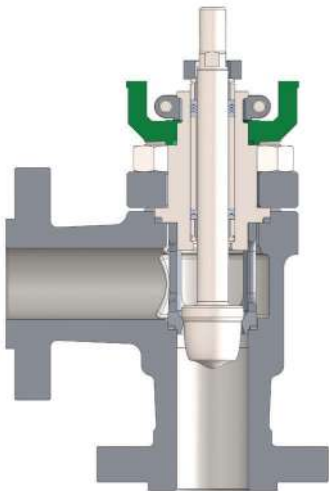


Figure 13: Angle Style Body

**Three Way** – Used to either combine or diverge the fluid, the OpGL 3Way configuration features a third port, dual seats, and extended plug.

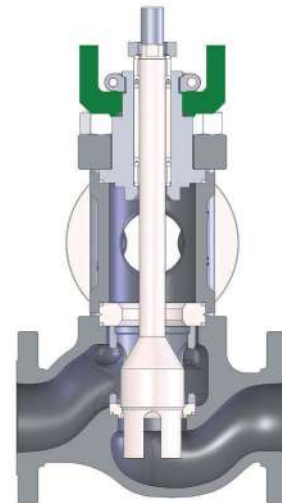
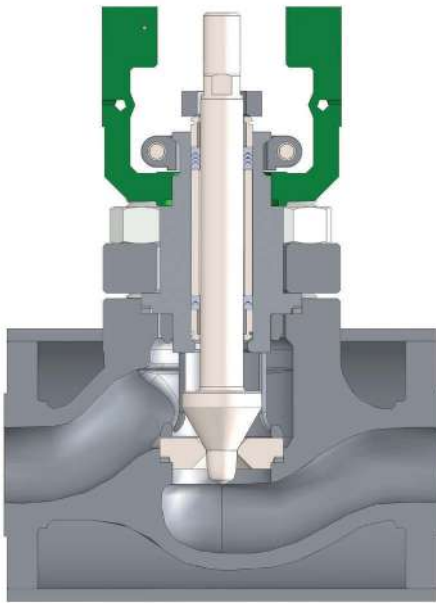


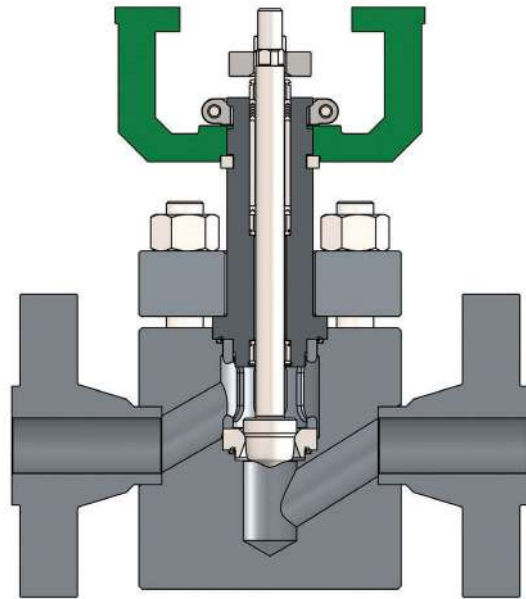
Figure 15: Three Way Body

**Steam Jacketed** – This style features a standard OpGL Globe Style Body with oversized blind integral flanges for full jacket (standard integral flanges for partial jacket). Trimteck’s steam jackets are rated to 150 PSI (10.3 barg) and feature an NPT drain plug.



**Figure 16: Steam Jacketed Body**

**Fabricated** – Trimteck’s XT, or fabricated, bodies are machined using bar stock and thus not subject to foundry delays, a bar stock body is a great solution for high pressure and special alloys – available with a variety of end connections.



**Figure 17: XT Fabricated Body**

**Table 7: Body Materials**

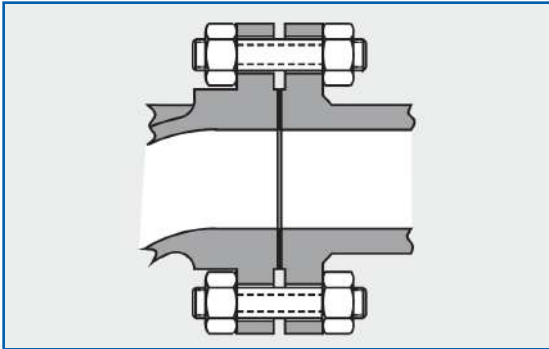
Table 7: Body Materials	
<b>Materials</b>	Standard: A216 WCB, LCC, A351 CF8M
	By Request: Monel Nickel, Chrome-Moly, Titanium, Alloy 20, Aluminum Bronze, Hastelloy, Duplex, Super Duplex and other materials

**Table 8: Bonnet Materials**

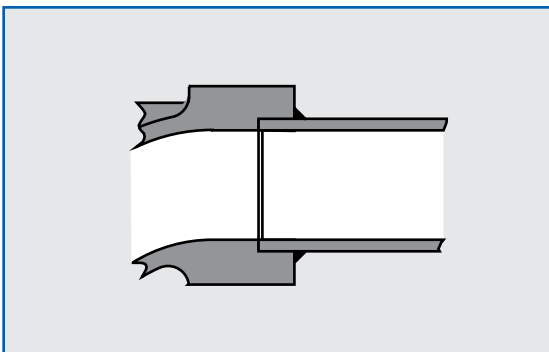
Table 8: Bonnet Materials	
<b>Types</b>	Standard, Extended, Special length extended, Bellows seal, Cryogenic
<b>Bonnet Flanges</b>	Separable, Bolted
<b>Material</b>	Bonnet: Same as body Bellows: Stainless Steel, other material as required Bellows Housing: Carbon Steel, 316 Stainless Steel, other materials as required Bonnet Flange: Carbon Steel, 316 Stainless Steel, other materials as required

**OpGL™**  
Globe Control Valve

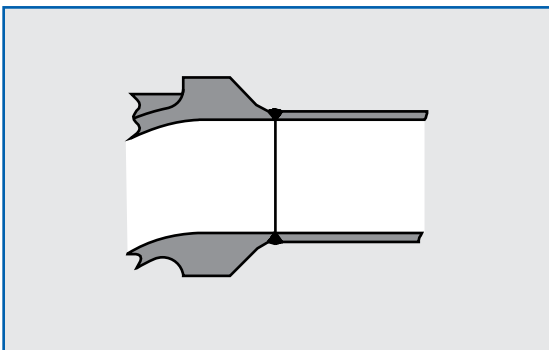
End Connections



**Fig. 18: Integral Flanges**



**Fig. 19: Socketweld (SW)**



**Fig. 20: Butt weld (BW)**

Trimteck’s standard end connections for OpGL bodies are raised face (RF) integral flanges with standard ANSI/ISA face-to-face dimensions. Options include NPT, RTJ, Butt weld, Socketweld, Grayloc, and others.

For ANSI Class 150 through 600 valves up to 10”, standard wall thickness of the body is ANSI Class 600 and the flange bolt patterns and face-to-face dimensions change accordingly if the valve requires ANSI Class 150 or 300 end connections. Therefore, in the case of ANSI Class 150 and 300, the user is getting a more robust body, which has the benefit of a longer lifecycle in erosive and corrosive applications.

<b>Table 9: End Connections</b>		
<b>End Connections</b>	<b>Valve Size (Inches)</b>	<b>ANSI Class</b>
<b>Integral Flange</b>	1/2 - 24	150 - 2500
<b>NPT</b>	1/2 - 2	150 - 2500
<b>Socket Weld (SW)</b>	1/2 - 2	150 - 2500
<b>Butt Weld (BW)</b>	3 - 24	150 - 600
	1/2 - 24	900 - 2500

**Note: In compliance with ANSI/ISA S75.03**

**Bonnet Flanges & Bolting**

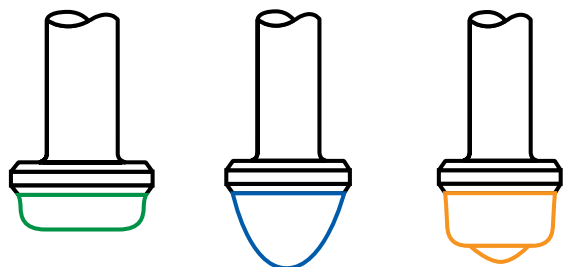
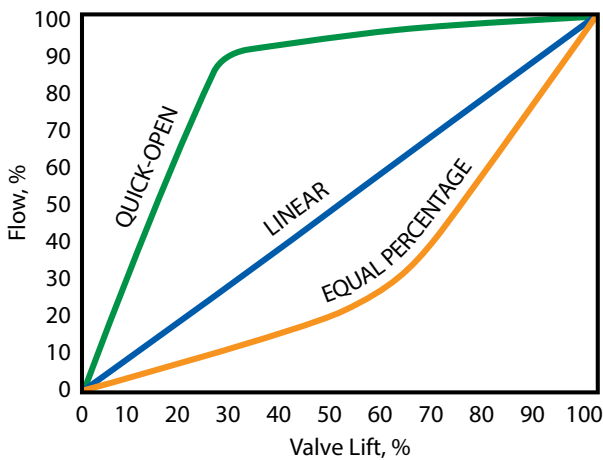
The OpGL bonnet has a separate flange that attaches it to the body. Bonnet flange material is typically selected to match the body material, however, because it is not a wetted component it can be selected of a more economical metallurgy should the customer request it.

Bonnet flange bolting consists of studs and nuts – typically in 304 or 316 stainless steels – and specified according to the latest edition of ANSI B16.34 depending on process pressures and temperatures.

# OpGL™ Globe Control Valve

## Flow Characteristics

A valve's flow characteristic is the relationship between the valve coefficient (Cv) and the valve stroke. As a valve opens, the flow characteristic, which is inherent to the design of the selected valve, allows a certain amount of flow through the valve at a particular percentage of the stroke. This is what allows a valve to control the flow in a predictable manner. In the case of the OpGL, the characteristic is inherent in the geometry of the plug head so that flow is controlled immediately once the plug lifts off of the seat – this offers a much broader range of control than cage-characterized valves i.e. ~5% to 95% open versus ~30% to 70% open respectively..



Quick-Open      Linear      Equal Percent

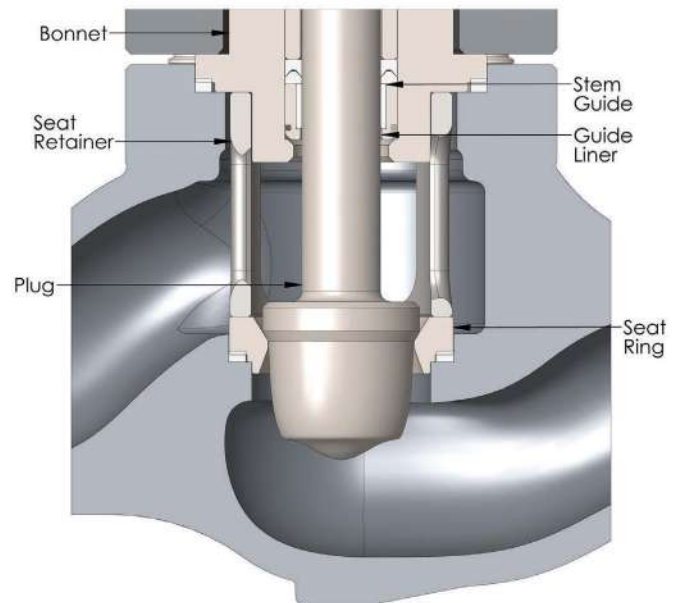
**Figure 21: Flow Characteristics**

## Trim

The OpGL's standard unbalanced trim is designed to avoid many of the issues associated with cage-guided valves – some mechanical, such as preventing galling and corrosive sticking of the seat into the body; and some control-related, such as broadening rangeability and increasing the valve's resolution.

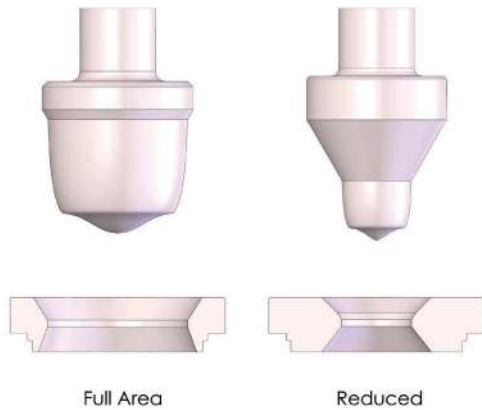
For some high-pressure drop applications, the OpGL has a balanced trim option to assist the actuator in stroking the plug through its range. Moreover, Trimteck offers an array of Severe Service Trims for controlling cavitation and minimizing noise.

Both balanced and unbalanced OpGL trim can be full area or reduced to achieve optimal Cv for each size valve.

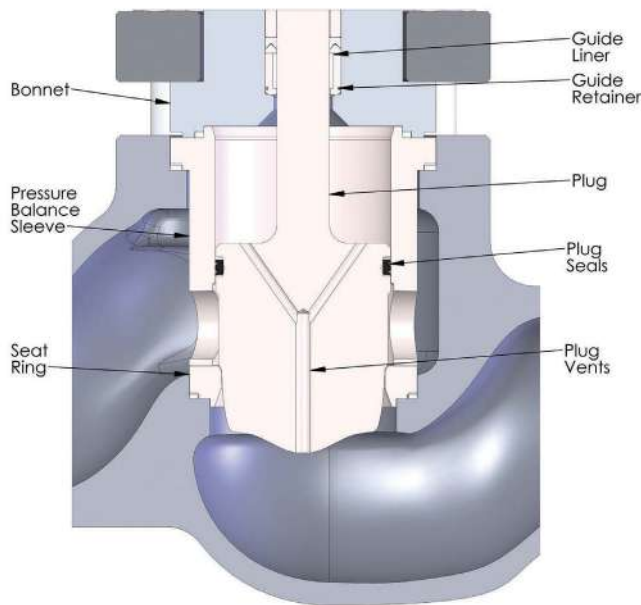


**Figure 22: Unbalanced Trim**

# OpGL™ Globe Control Valve



**Figure 23: Full Area & Reduced Trim**



**Figure 24: Balanced Trim**

## Seats

All OpGL seats are of a self-centering, clamped-in design. Self-centering refers to the fact that the seat will align itself with the plug the first time the valve is stroked closed. Clamped-in refers to the fact that the seat retainer transfers the force exercised on the bonnet bolting to clamp the seat into the body eliminating the need for threading and allowing the seat to be removed even after years in extremely corrosive service.

**Metal Seats** – all OpGL Globe Control Valves are ANSI Seat Leak tested prior to being delivered to the customer, and our metal seats routinely test to ANSI Class V though ANSI Class IV is common in certain services.

**Soft Seats** – for ANSI Leakage Class VI, or bubble tight, applications, the OpGL can be configured with a soft seat consisting of a temperature-appropriate elastomer sandwiched between two metal parts.

**Table 10: Balanced Plug Seal Materials**

Table 10: Balanced Plug Seal Materials	
<b>Teflon Seal</b>	-320°F @ Full Body rating or 300°F @ 150psig
<b>PBI Carbon Core w/ Inconel Wire</b>	-22°F to 800°F
<b>Buna-N O-Rings</b>	-60°F to 250°F
<b>Spring-Reinforced TFE</b>	-365°F to 575°F
<b>Viton</b>	-40°F to 437°F

# OpGL™ Globe Control Valve

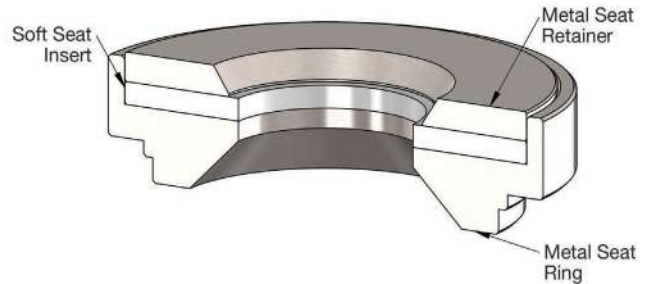
**Table 11: Soft Seat Materials**

Table 11: Soft Seat Materials	
<b>Materials</b>	Virgin PTFE
	KEL-F (PCTFE)
	PEEK
	Glass-filled PTFE

## Materials

As a standard, the OpGL is configured with plug and seat machined from 316 Stainless Steel. However, Trimteck offers a huge breadth of materials and material hardening processes in order to supply a control valve with internals that will stand up to even the harshest process conditions – whether they be corrosive, erosive, abrasive, cavitating, flashing, high temperature, or low temperature.

In addition to the more common hardening processes, such as Stellite 6 overlays, Trimteck has pioneered the use of CVD-5B, a chemical vapor deposition of boron wherein a hard metal mesh is fused into the base material. Unlike a coating, this deposition process permeates the material with a boride layer up to .015” deep. In many cases this increases the useful life of our valves by 10-fold.



**Figure 25: Soft Seat Configuration**



**Figure 26: CVD-5B**

**Table 12: Trim Material Characteristics**

Trim Material	Hardness Rockwell C	Impact Strength	Corrosion Resistance	Maximum Temp. Recomm.		Erosion Resistance	Abrasion Resistance
				°F	°C		
<b>316 Stainless Steel</b>	8	Excellent	Excellent	600	316	Fair	Fair
<b>Duplex 2205</b>	31	Excellent	Excellent	572	300	Fair	Fair
<b>Monel</b>	32	Good	Excellent	600	316	Fair-Good	Good
<b>416 Stainless Steel</b>	40	Good	Fair	800	427	Good	Good
<b>17-4PH (H900)</b>	44	Good	Good	800	427	Good	Good
<b>n° 6 Stellite</b>	44	Excellent	Excellent	1500	816	Good	Good
<b>440C Stainless Steel</b>	60	Fair	Fair	800	427	Excellent	Excellent
<b>Tungsten Carbide</b>	72	Fair	Good on Bases Poor on Acids	1200	649	Excellent	Excellent
<b>440C + CVD-5B</b>	72	Excellent	Good	1200	649	Excellent	Excellent



# OpGL™ Globe Control Valve

**Table 13: Wear and Galling Resistance of Material Combinations**

	304 Stainless Steel	316 Stainless Steel	Bronze	Inconel 600	Monel 400	Hastelloy B	Hastelloy C	Titanium 75A	Nickel	Alloy 20	416 Hard.	440 Hard.	17-4 PH	Stellite	NDE*	Cr. Plate	Al. Bronze
304 Stainless Steel	P	P	G	P	P	P	G	P	P	P	G	G	G	G	G	G	G
316 Stainless Steel	P	P	G	P	P	P	G	P	P	P	G	G	G	G	G	G	G
Bronze	G	G	E	E	E	E	E	E	E	E	G	G	G	G	G	G	G
Inconel 600	P	P	E	P	P	P	G	P	G	G	G	G	G	G	G	G	E
Monel 400	P	P	E	P	P	P	G	G	G	G	G	G	G	E	G	G	E
Hastelloy B	P	P	E	P	P	P	G	G	E	G	G	G	G	E	G	E	E
Hastelloy C	P	P	E	P	P	P	G	G	E	G	G	G	G	E	G	E	E
Titanium 75A	P	P	E	P	G	G	G	P	G	G	G	G	G	E	G	G	E
Nickel	P	P	E	G	G	E	G	G	P	P	G	G	G	E	G	G	E
Alloy 20	P	P	E	G	G	G	G	G	P	P	G	G	G	E	G	G	E
416 Hard.	G	G	G	G	G	G	G	G	G	G	G	G	G	E	E	E	E
440 Hard.	G	G	G	G	G	G	G	G	G	G	E	G	E	E	E	E	E
17-4 PH	G	G	G	G	G	G	G	G	G	G	G	E	P	E	E	E	E
Stellite	G	G	G	G	E	E	E	E	E	E	E	E	E	E	E	E	E
NDE*	G	G	G	G	G	G	G	G	G	G	E	E	E	E	P	E	E
Cr. Plate	G	G	G	G	G	E	E	G	G	G	E	E	E	E	E	P	P
Al. Bronze	G	G	G	E	E	E	E	E	E	E	E	E	E	E	E	E	P

E: Excellent, B: Good, P: Poor

\* Electrolytic Nickel Coating

**Table 14: Pressure Differential (PSI) Requiring Hardened Seating Surfaces**

Valve Size (inches)	Gases (Clean)				Steam (Superheated)				Steam (Saturated)				Water				Process Fluids (General)			
	Control		On-Off		Control		On-Off		Control		On-Off		Control		On-Off		Control		On-Off	
	Psi	Bar	Psi	Bar	Psi	Bar	Psi	Bar	Psi	Bar	Psi	Bar	Psi	Bar	Psi	Bar	Psi	Bar	Psi	Bar
1/2 - 1 1/2	600	41	900	62	300	21	600	41	100	7	200	14	175	12	250	17	175	12	250	17
2 - 3	350	24	600	41	200	14	300	21	25	2	50	3	150	11	200	14	150	10	200	14
4 - 6	200	14	300	21	100	7	150	10	All		25	2	100	7	125	9	75	5	125	9
8 - 12	125	9	175	12	50	3	100	7	All applications				50	3	100	7	50	3	100	7

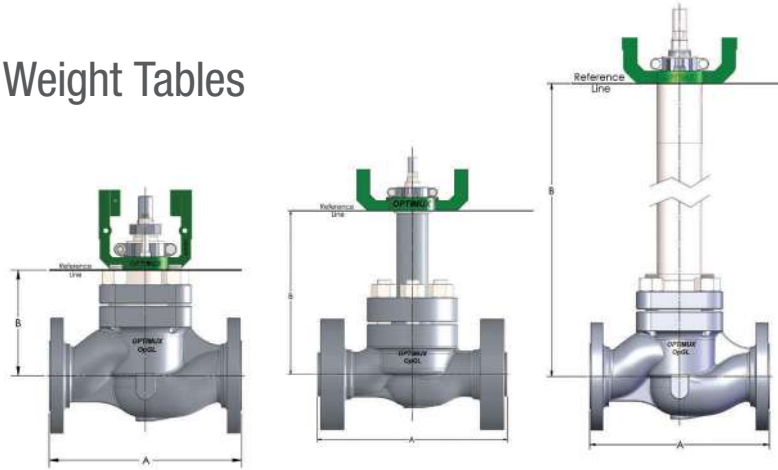








Dimensions & Weight Tables



**Table 19: Valve Dimensions - Class 150-300-600**

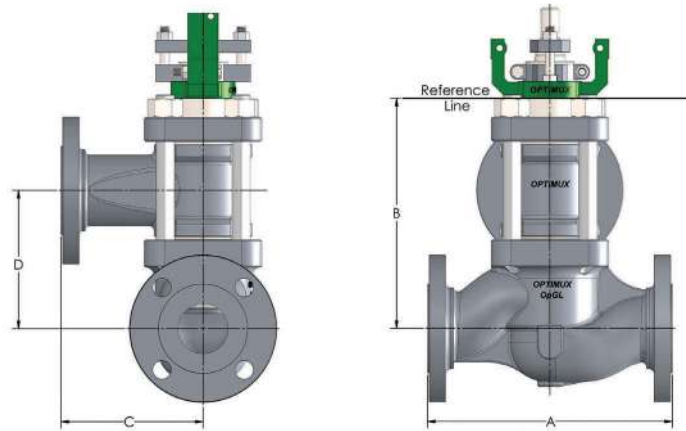
Body Size (Inch)	A						B						Space Needed for Disassembling Above Actuator	
	ANSI/ISA						Standard Bonnet		Extended Bonnet		Cryogenic Bonnet			
	Class 150		Class 300		Class 600		Inch	mm	Inch	mm	Inch	mm	Inch	mm
	Inch	mm	Inch	mm	Inch	mm								
1/2 & 3/4	7.30	185	7.60	193	8.10	206	3.84	98	8.42	214	17.80	452	2.50	64
1	7.30	185	7.80	198	8.30	211	3.84	98	8.42	214	17.80	452	2.50	64
1 1/2	8.80	224	9.30	236	9.90	251	5.22	133	9.70	246	20.20	513	4.00	102
2	10.00	254	10.50	267	11.30	287	5.48	139	9.98	253	20.50	521	4.50	114
3	11.80	300	12.50	318	13.30	338	6.89	175	12.38	314	21.90	556	5.80	147
4	13.90	353	14.50	368	15.50	394	8.62	219	14.13	359	24.00	610	7.50	191
6	17.80	452					10.14	258	15.60	396	26.50	673	10.00	254
6			18.60	472	20.00	508	12.48	317	17.80	452	26.50	673	10.00	254
8	21.40	544					12.92	328	18.00	457			11.40	290
8			22.40	569	24.00	610	14.72	374	20.25	514			11.40	290
10	26.50	673					14.30	363					11.90	302
10			27.90	709	29.60	752	16.31	414					12.10	307
12	29.00	737					17.31	440					12.60	320
12			30.50	775	32.30	820	17.31	440					12.60	320

**Table 20: Valve Dimensions - Class 900-1500-2500**

Body Size (Inch)	A				B								Space Needed for Disassembling			
	Distance Between Flanges				Standard Bonnet				Extended Bonnet							
	Class 900/1500		Class 2500		Class 900/1500		Class 2500		Class 900/1500		Class 2500		Class 900/1500		Class 2500	
	Inch	mm	Inch	mm	Inch	mm	Inch	mm	Inch	mm	Inch	mm	Inch	mm	Inch	mm
1	11.00	279	12.02	305	6.10	155	6.80	173	10.10	257	11.30	287	3.60	91	3.60	91
1 1/2	13.00	330	15.01	381	9.10	231	8.70	221	13.20	335	13.20	335	5.60	142	5.60	142
2	14.80	376	15.80	401	9.10	231	8.70	221	13.20	335	13.20	335	6.10	155	6.10	155
3	18.10	460	26.01	661	10.90	277	12.90	328	18.40	467	19.90	505	8.40	213	8.30	211
4	20.90	531	29.01	737	12.40	315	14.60	371	19.40	493	21.60	549	9.70	246	10.70	272
6	30.02	763	34.01	864	16.40	417	17.40	442	23.40	594	27.30	693	12.20	310	13.60	345
8	32.80	833	40.30	1024	18.60	472	24.30	617	24.20	615	31.30	795	16.70	424	17.80	452
10	39.00	991	50.00	1270	21.90	556	26.00	660	28.90	734	33.00	838	18.30	465	19.50	495
12	44.50	1130	56.00	1422	26.60	676	28.00	711	33.60	853	35.00	889	19.40	493	20.50	521
14	49.50	1257			24.80	630			31.80	808			20.50	521		

**OpGL™**

## Dimensions & Weight Tables



**Table 21: 3-Way Valve Dimensions - Class 150-300-600**

Body Size (Inch)	A						B				C		D		Space Needed for Disassembling above Actuator	
	ANSI/ISA						Standard Bonnet	Extended Bonnet								
	Class 150		Class 300		Class 600				Inch	mm	Inch	mm				
	Inch	mm	Inch	mm	Inch	mm	Inch	mm					Inch	mm		
1/2 & 3/4	7.30	185	7.60	193	8.10	206	6.70	170	11.20	284	4.30	109	3.40	86	3.40	86
1	7.30	185	7.80	198	8.30	211	6.70	170	11.20	284	4.30	109	3.40	86	3.40	86
1 1/2	8.80	224	9.30	236	9.90	251	9.10	231	13.40	340	4.80	122	5.40	137	5.00	127
2	10.00	254	10.50	267	11.30	287	9.30	236	13.70	348	5.80	147	5.60	142	5.50	140
3	11.80	300	12.50	318	13.30	338	13.00	330	18.50	470	7.00	178	7.60	193	7.10	180
4	13.90	353	14.50	368	15.50	394	16.70	424	22.10	561	8.50	216	9.90	251	9.40	239
6	17.80	452					21.60	549	26.60	676	8.90	226	14.00	356	11.60	295
6			18.60	472	20.00	508	25.80	655	31.30	795	10.00	254	16.00	406	11.60	295
8	21.40	544					23.90	607	29.40	747	10.70	272	15.00	381	12.20	310
8			22.40	569	24.00	610	30.20	767	35.70	907	12.00	305	18.30	465	12.20	310

**Table 22: Estimated Shipping Weights**

Size (Inches)	Weight in Pounds / Kilograms												Add for Extended Bonnet	
	Class 150		Class 300		Class 600		Class 900		Class 1500		Class 2500			
	lbs	Kg	lbs	Kg	lbs	Kg	lbs	Kg	lbs	Kg	lbs	Kg	lbs	Kg
1/2 - 3/4	40	18	40	18	40	18							5	2
1	50	23	50	23	50	23	100	45	120	54	150	68	5	2
1 1/2	65	29	65	29	65	29	170	77	180	82	210	95	5	2
2	75	34	75	34	75	34	200	91	220	100	300	136	5	2
3	160	73	170	77	180	82	400	181	430	195	500	227	15	7
4	240	109	250	113	365	166	590	268	610	277	940	426	20	9
6	360	163	570	259	600	272	1000	454	1170	531	1400	635	40	18
8	590	268	790	358	830	376	1100	499	1320	599	1740	789	65	30
10	1050	476	1405	637	1600	726	2050	930	2200	998	2600	1179	90	41

## **OpGL™**

The information and specifications described in this document are considered accurate. However, they are intended for informational purposes only. Any specification and selection of the products herein described should be reviewed by a Trimteck applications engineer.

Trimteck products are continuously improved and upgraded. Therefore the information herein is subject to change without notice.

For further information about this product, consult your local Authorized Trimteck Sales Representative, Distributor, or Certified Service Center. Instructions for installation, operation, preventive maintenance, and troubleshooting are contained in the OpGL Globe Control Valve Product Instruction Manual (PIM).

*For more information visit our website at [www.trimteck.com](http://www.trimteck.com)*

*[www.cvcontrol.com.ar](http://www.cvcontrol.com.ar)*

